



TRUST IN QUALITY



Glassroof

By Ultraframe

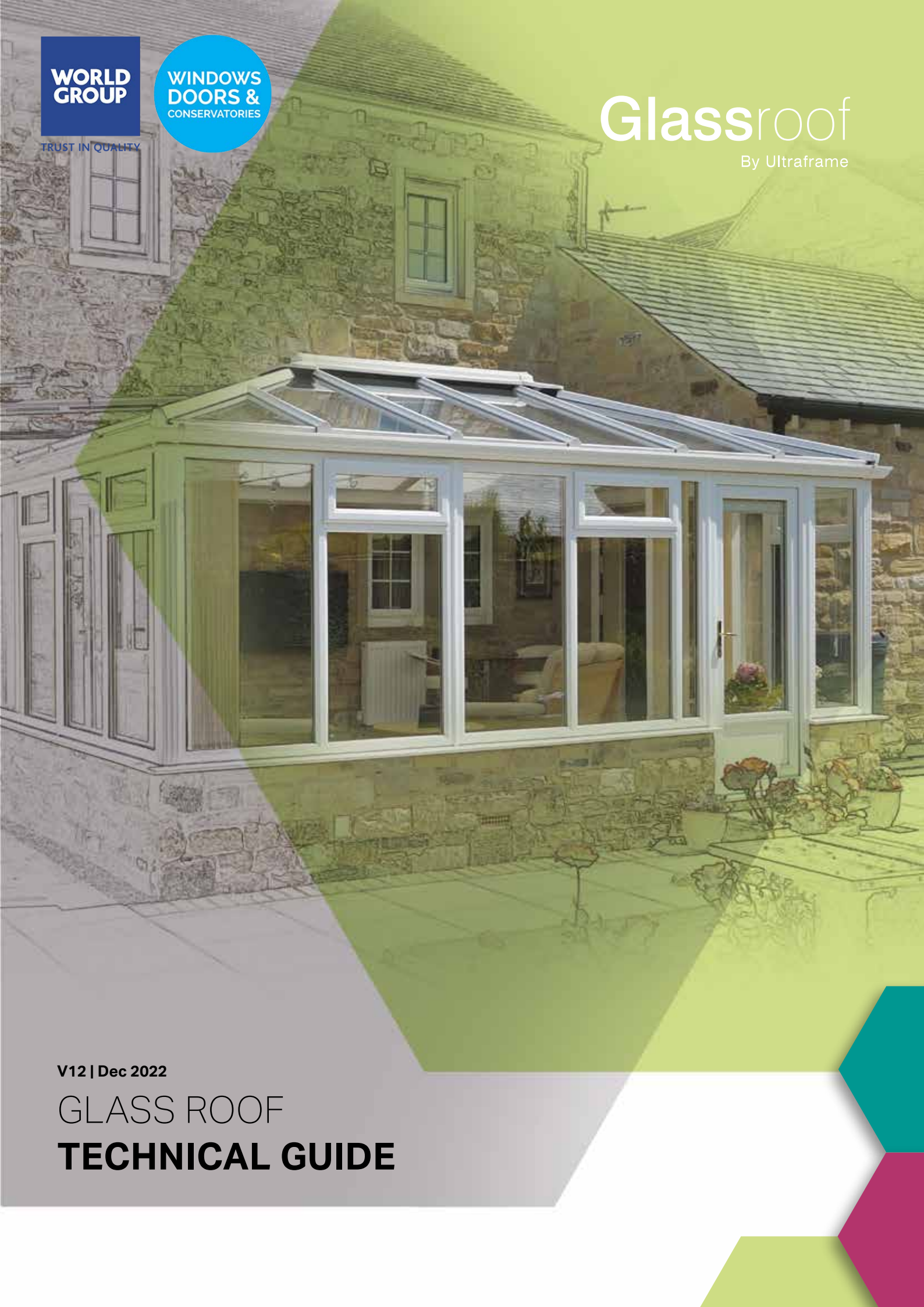

V12 | Dec 2022

GLASS ROOF TECHNICAL GUIDE

DEAR TRADE PARTNER OR CONSERVATORY BUYER,

The Ultraframe roof is the market leader, having established itself in 1983 and having continuously serviced the conservatory industry for all that time. Through constant and consistent innovation, the Ultraframe Glass roof brand has led the way.



WEATHER TESTED

Watertight in winds up to 130mph

- **Triple layer storm shield** at radius end.
- Unique **double skin** top caps and **adjustable speedlocks** designed to optimise glazing bar compression.
- Sturdiest, most **durable** gaskets and glazing stops.



EASIEST

The simple and most intuitive to fit

- Click-fit speedlocks and top-caps.
- Loaded with features for a **fast fit, first time**, every time.
- **No cutting or drilling** on site.
- Comprehensive installation guides and videos.



VERSATILE

The most configurable roofing system available

- Low pitch eaves beam and variable ridges for **pitches from 2.5 to 40.9°**.
- **Advanced software** to instantly validate structural requirements of any large shape and complex designs.
- Integrated structural solutions for **large spans** of bi-folding doors.



TRUSTED

The original and most loved glazed roof

- Over **1.5 millions roofs** installed.
- The first roofing system to be **approved by BBA**.
- **Made in Britain** for over 35 years.



SAFEST

The only roof engineered to postcode

- NASA satellite data used to calculate the maximum wind AND snow load requirements.
- Specialist software engineers every critical element of the roof for optimum deflection, compression and tension.
- **Super strong** eaves beam, ridge, valley and jack rafter.



CUSTOMISABLE

Unbeatable range of design options

- Add shape and elegance externally with a choice of **4 unique Cornices**.
- Create thermally efficient, cosy and stylish rooms with **insulated pelmets and columns**.
- **Bespoke colours** in painted aluminium or foiled.
- **Finishings and crestings** to suit all tastes and budgets.



The Glass conservatory roof is the choice of national brands, regional home improvement companies and indeed local builders.

The Glass roof is tried, tested and trusted. Third party accreditation from the British Board of Agrément is just the start as Ultraframe subjected it's roof to 130mph winds at Wintech to check how the roof performed in the worst wind and rain conditions in the British Isles. Ask to see the 7 minute DVD which shows the full test in more detail.

This brochure highlights what the Glass roof system can achieve, including standard and non standard conservatories but also exploring how the Glass roof system is used to create other crossover buildings like Orangeries and home extensions. Our systems are designed to be class leading in energy saving measures.

We even show you how and why the Glass roof is technically superior to other alternatives. **Take your time to familiarise yourself with the contents of the brochure to find out how using Ultraframe can transform light and space in the home.**

For assistance with roof design or specification please contact the Technical Support Team on 01200 452918 or email techsupport@ultraframe.co.uk

NOT COVERED IN THIS GUIDE:
Livinroof and Super-insulated column

CONTENTS

section 1 Our Design Philosophy 4 - 7

SECTION 2 - 7: Examines in detail the Glass roof in its application to standard Conservatories

section 2 Ridge system / Wallplate 8 - 9

section 3 Glazing bars 10 - 12

section 4 Tie bars 13

section 5 Eaves and box gutters 14 - 20

section 6 Other items - Valley 21 - 23

section 7 Other items - Ventilation 24

section 8 Other items - Conservaflash 25 - 26

section 9 Glazing options 27 - 28

section 10 Colours and finishes 29 - 30

SECTION 11: Looks at how the Glass Roof is used on non standard conservatories

section 11 Additional conservatory designs (Pagoda, 'Wok', lantern) 31 - 32

SECTION 12: Examines linked technologies which can be used on the Glass roof

section 12 Aluminium externals 33 - 34

SECTION 13-14: Highlights how the Glass Roof is used for cross-over extensions

section 13 Insulated Internal Pelmet 35

section 14 Veranda Glass Extensions 36

section 15 Compare the Ultraframe Glass Roof ... with 'alternative' systems 37 - 38

section 16 Hup! Wall 39

* Many of the options displayed in this brochure are chargeable. Please ensure that any options chosen are made clear at point of sale.



Please read with our accompanying guides - surveyors guide and Glass Installation guide.

OUR DESIGN PHILOSOPHY

For over 30 years Ultraframe has been dedicated to designing and manufacturing conservatory roofs. In that time we have supplied approaching 1½ million roofs, not only to all corners of the UK, but to countries with even more extreme climates like Russia and the USA.

Each and every day Ultraframe Glass roofs are performing in the most extreme conditions... this is the ultimate peace of mind. Ultraframe roofs. Tried. Tested. Trusted.



But there is more to Ultraframe than just our superbly performing roofs. There is the quality marketing support and promotional materials that only the market leader can deliver. On this and the next few pages are just a few examples of the items that make using and choosing the Ultraframe brand a truly positive experience.



STRUCTURAL DESIGN GUIDELINES

Ultraframe – as the market leading brand – wants to ensure that its customers and users are working to the best codes/design standards. Most domestic conservatories are exempt from Building Regulations and so most of the time a conservatory didn't need to comply with BS6399 but Ultraframe's brand positioning was that each roof was designed to a postcode and was more than fit for purpose (peace of mind). BS6399 has now been superseded by Eurocodes and Ultraframe is now working to these. In order to pass building regulations, all conservatory over 2.5m wide will need a glass U-value of at least 1.2. Smaller conservatories will need glass to be specified with 1.0 U-value. The thermal design guide within UDesign will provide the specific U-Value of each glass roof.

By updating to Eurocodes we are ensuring the roof stay ahead of competitors and continues to be well positioned should for example CE Marking become mandatory on the roof in the future

Ultraframe uses software called U-Design inside which is an electronic rule book of structural guidelines called eSDG. The eSDG has been updated to include;

- Eurocodes now in place of BS 6399 which is obsolete.
- BreVe (which supplies the weather data inside eSDG) has finally fully adopted the Eurocodes and therefore the wind and snow loading they provide into U-Design has also been updated.
- The wind and snow loads in Eurocode are calculated differently and have also been revised with more updated average wind and ground snow loads in the UK. Previously BS6399 used a General Design approach which meant looking at the maximum wind speeds over a large area around the site which meant that the loads could be larger than necessary. Eurocode uses a directional approach based on the average mean wind speed and probability factor of exceeding this. The calculated wind load using this method is lower. We have looked at a number of different postcodes around the UK (a mixture of city centre, town outskirts, countryside and coastal locations) and have looked at

CERTIFICATE OF AUTHENTICITY

Conservatory roofs are sent to site with a registration form that the fitter passes to the homeowner, who then registers with Ultraframe and in return receives a 'Certificate of Authenticity', confirming that they have had the genuine Ultraframe product installed. They also receive a FREE conservatory maintenance manual with hints and tips on how to care for the new conservatory.

AS PART OF OUR PHILOSOPHY...

We want to make trading between our trade partners and us, easy and error free. That's why our vision is to receive orders electronically from our trade partners. In fact, we encourage our partners to design a conservatory in the home or showroom, structurally prove it and 'fire it' through for computerised manufacturing, virtually untouched by human hands!



U-Design software visualisers and designs conservatories

We rigorously tested our roof and alternatives - ask for the DVD of the aero engine at the Wintech Test Centre



the current output on the SDG and compared this with the new outputs. In all instances the wind load has reduced.

- BreVe has also changed how they locate postcode data. Previously they used information from Ordnance Survey and now they are obtaining this from NASA. In addition they have improved the way they pinpoint this information making the information more accurate. This means that some altitudes will change which affects the snow load calculations.

ADDITIONAL NOTES:

1. This means that roof projects are now more accurately specified for loads than before - this does not mean that we were wrong before just that we have improved the way the loads are calculated based on the latest information available.
2. As with BS6399, the software is looking at the loadings and the specification of the roof only, not the whole structure.
3. There is a distinct possibility that a roof MAY have a lower cost now based on Eurocodes than previously.



Ultraframe's products are pre-approved to meet Building Regulations, so there's less red tape!

OUR DESIGN PHILOSOPHY - CONTINUED

Exact design, meticulous specification / manufacturing and comprehensive service back up - all these attributes combine to make Ultraframe the brand of choice for both the trade and homeowners.

As you will see as you thumb through this technology guide, there is virtually nothing Ultraframe cannot do. From straight forward traditional conservatories through to high end complex shapes and to the next generation of crossover glazed extensions, the Ultraframe Glass roof is at the heart of each beautifully engineered construction that will deliver enjoyment for years and years.

Lets look at a number of other factors that make the Ultraframe roof unsurpassable...

TECHNICAL SUPPORT

Everyone assumes technical support is a retrospective activity, usually after problems arise. At Ultraframe we believe it's easier and less stressful to provide support up front and have a technical team on hand to support our trade partners at all stages of the process from enquiry through to installation helping overcome any technical challenges that may arise during the design process or on site. On the rare occasion when retrospective support is required, our technical team work with installers remotely using video calls or photographs to help understand the issue and provide advice.

To demonstrate the lengths we go to we even produce a 'Jargon Manual' to help those new to the industry understand all the terminology.

- you can even search online if you are unsure!



TECHNICAL TRAINING

The Ultraframe School of Excellence is ever popular. The technical training and sales courses cover surveying, installation, ordering and of course sales benefits and are aimed at all in the conservatory supply chain both at retail or trade level.

The courses can be delivered at the Head Office in Clitheroe or off site at a location of the customers choosing.



For further information and to obtain course outlines, email training@ultraframe.co.uk

Phil Wharf (left) with Lee Barratt of Elephant Windows in Kent – Lee holds his course certificate from his first course at Ultraframe, 20 years ago!



ACCREDITATION / TESTING

In 1996, Ultraframe was the first roof system company to obtain British Board of Agrément approval for its products.

As we were the first in our sector, we worked with the BBA to define the testing regime that has now been adopted for all conservatory roof assessments.

Ultraframe doesn't just rely on third party creditations, it undertakes its own testing on wind/snow loadings and of course durability/ stability tests.



Ask to see the DVD of Ultraframes's roof being tested with 130mph winds.

Ultraframe's products are pre-approved to meet Building Regulations, so there's less red tape!



AWARDS

Ultraframe is thrilled to have been awarded Conservatory Roof Fabricator/Manufacturer of the Year at the 2020 National Fenestration Awards (NFA's).

Founded in 2013 The NFA's aim to recognise all facets of the UK fenestration industry by inviting nominations for companies deserving recognition, followed by voting by the industry. There are no judges and no panels – the winners of the various awards are decided completely by industry participation.



At the glazing industry home improvement 'oscar's', held in November each year, Ultraframe won 'Health and Safety Initiative' of the year in 2011, 'Retail promotional campaign of the year' in 2012 for its Loggia technology and 'Product of the year' in 2014 for Livinroof, the replacement solid roof.



MANUFACTURING PROCESS

Sector leaders like Ultraframe have a duty to lead. That's why we are passionate about the 3 'R's' - reduce, reuse and recycle. Wherever possible, we look to reduce waste (including site packaging).

This drive to become more lean reduces our costs directly leading to further investment, innovation and value. In 2007 we won the Cranfield best Factory Award, in 2009 the Shingo Prize for Operational Efficiency and in 2010 the Best Finance Award.



THE GLASS ROOF SYSTEM - RIDGE

The Glass roof ridge can accommodate a pitch range of between 15-40° and 45° on gable designs, it is ventilated as standard through the ridge or wallplate. (see page 21 for further details)

FEATURES

At the intersection with the host wall, the Glass roof system features an integrated flashing trim to ensure rain water is shed away from this area. At the other end of the ridge, it features a geometrically correct 'hub' arrangement, which allows placement of glazing bars to create perfect alignment of the glazing material. Second generation speedlocks take care of the engagement of the bars into the die cast aluminium hub. A weatherproof secondary 'tray' sits over the die cast hub and fits snugly under the PVCu end cover.

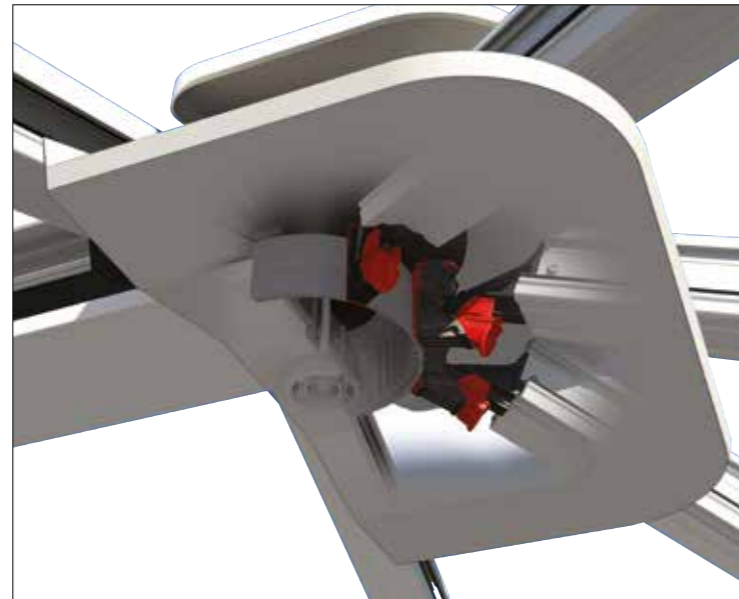
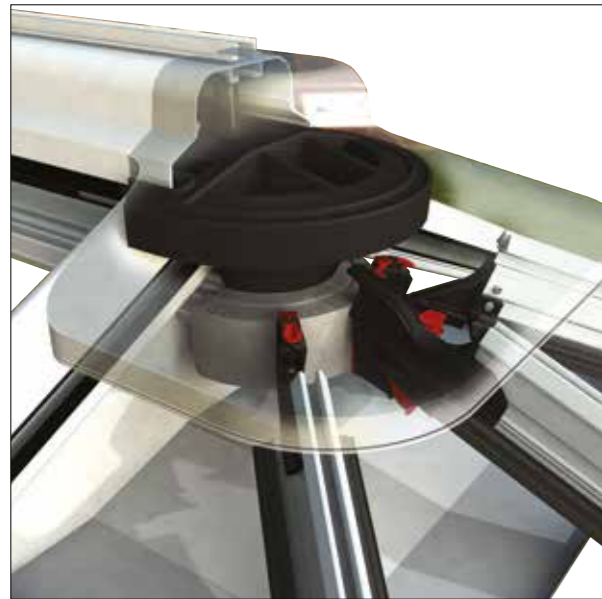

SLIMLINE - RIDGE

The super strong slimline ridge is 30% slimmer (53mm) than the Classic ridge which creates a minimalist contemporary design.

The slimline ridge can only be used on a fixed pitch of 25° on Georgian or Double hipped Georgian shapes only.

Includes the unique stormshield protection system that provides a triple layer protection against extreme weather at the ridge ends.

As standard the ridge is aluminium external and available with uPVC and aluminium bars. Can be used with insulated pelmet, cornice and super insulated columns.



PVCU CRESTINGS AND FINIALS

A choice of six different PVCu finials and six crestings allows you to personalise the conservatory. Whichever style of cresting and finial combination chosen, rest assured the Ultraframe roof will be stylish and weatherproof.

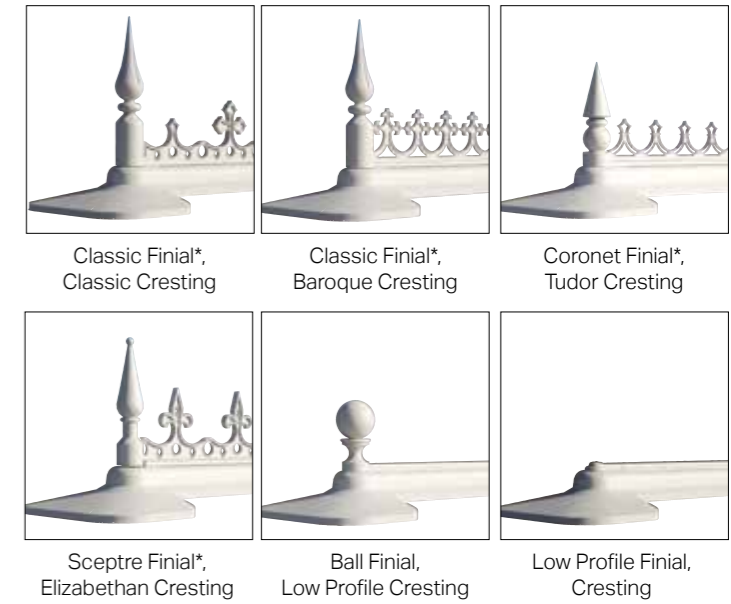
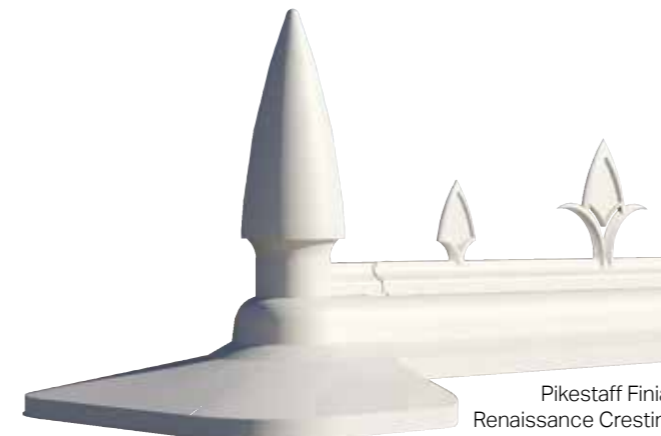

Classic Finial*,
Classic Cresting

Classic Finial*,
Baroque Cresting

Coronet Finial*,
Tudor Cresting



Sceptre Finial*,
Elizabethan Cresting

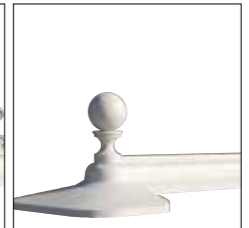

Ball Finial,
Low Profile Cresting



Low Profile Finial,
Cresting

The Pikestaff finial and Renaissance cresting feature additional benefits over the other PVCu finial/cresting options:

- EASY RUN - A streamlined body shape to help rainwater run off
- EASY FITTING - The cresting simply snaps over the existing track on the extruded ridge body, making it easier to fit.
- EASY CLEAN PVCu which stays clean longer and makes cleaning easier.
- Whichever of the options you choose, they are included in the roof price.

TECHNICAL SPECIFICATION

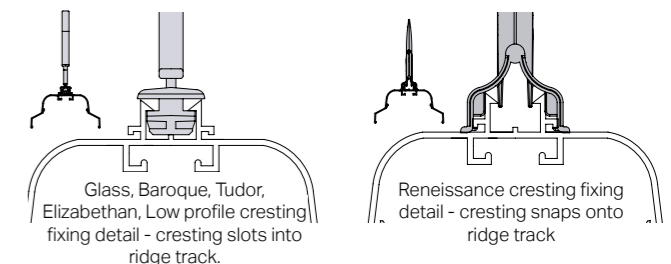

Glass, Baroque, Tudor,
Elizabethan, Low profile cresting
fixing detail - cresting slots into
ridge track.

Renaissance cresting fixing
detail - cresting snaps onto
ridge track

VENTILATED HALF RIDGE ASSEMBLY

This option is always specified on complex shaped roofs like 'P' or 'T' shapes. It can be specified for standard lean to roofs. (Upgrade option)



WALL PLATE ASSEMBLY

Selected as standard (ventilated) for basic lean to specification.

Unventilated low rise wall plate for certain situations



THE GLASS ROOF SYSTEM - GLAZING BARS

Glazing bars exist as 'suites' - with different shaped bars for differing applications. The wine aluminium profile is designed for maximum torsional rigidity and to resist both compression and wind uplift forces. Light and heavy versions of the aluminium exist.

SPECIFICATION

Glazing bars attach to the die cast aluminium ridge hub using Speedloks - click lock devices that allow speedy yet secure attachment.

The hub end can accommodate a maximum number of bars before the configuration software triggers the substitution of inter-rafter (see page 11).

Onto the aluminium glazing bars are attached PVCu chambered external top caps - the Glass roof also has a range of powder coated aluminium external claddings - see p30/31.

The chambered top caps are more insulated than standard single wall variants and are more resistant to the warping and twisting effect of solar heat gain, particularly when the roof is supplied in a dark colour.

GLAZING BAR TYPES - PVCU CHAMBERED TOP CAPS

See p30 - 31 for powder coated aluminium top caps

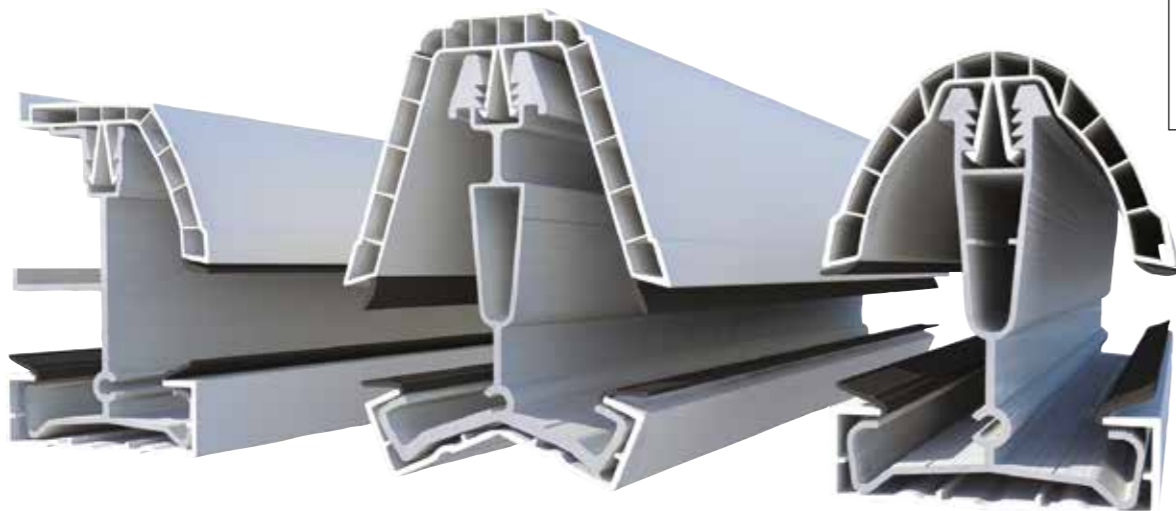

Starter - Chambered Capping

Georgian - Chambered Capping

Vic/Transom - Chambered Capping - main picture features Dome, bevelled version also available see inset.



A twin bolt slides into the captivated bolt slot in the eaves beam, prior to the glazing bar being tightened down. Vic/Transom glazing bars come in heavy, medium and light versions



Bar with speedlok attachment - ensures perfect glazing alignment.

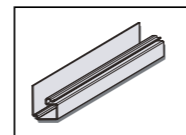
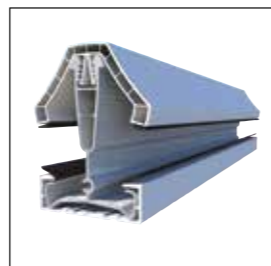

Optional soaker sits in starter bar - see p22



Since Feb 2016, the standard/default under cladding is DSBC

RE - INFORCED BARS AND BOLSTERS

Additional structural performance is needed in certain circumstances. Standard glazing bars can have steel reinforcement inserts.

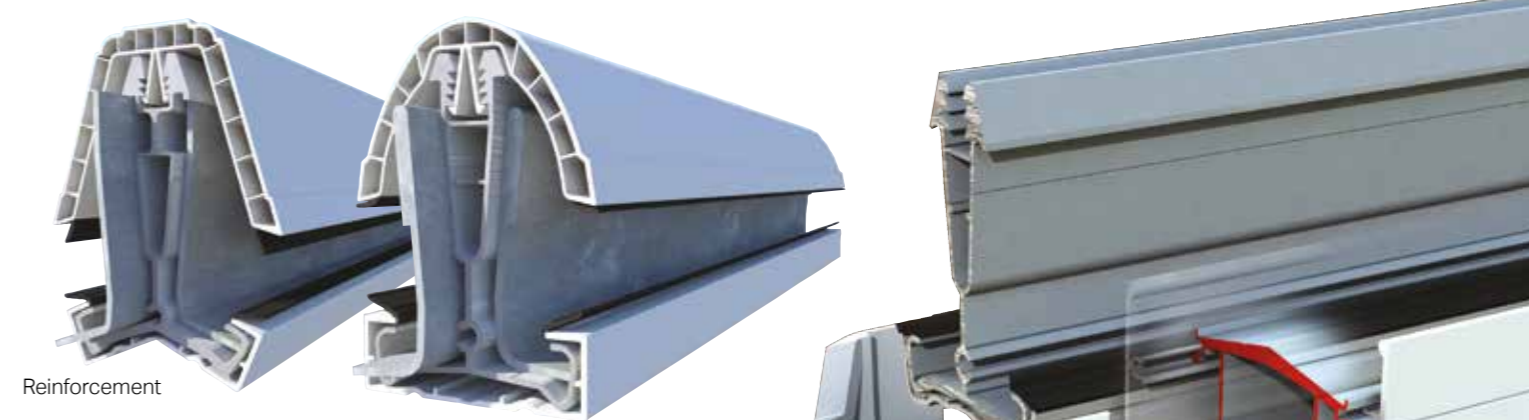

Reinforcement

A bolster is used when the conservatory span is too great for either the standard or reinforced glazing bar. This offers additional spanning performance of the glazing bar. The PVCu bolster cladding finishes shy of the ridge / wall plate and eaves and is finished with a PVCu end cap.

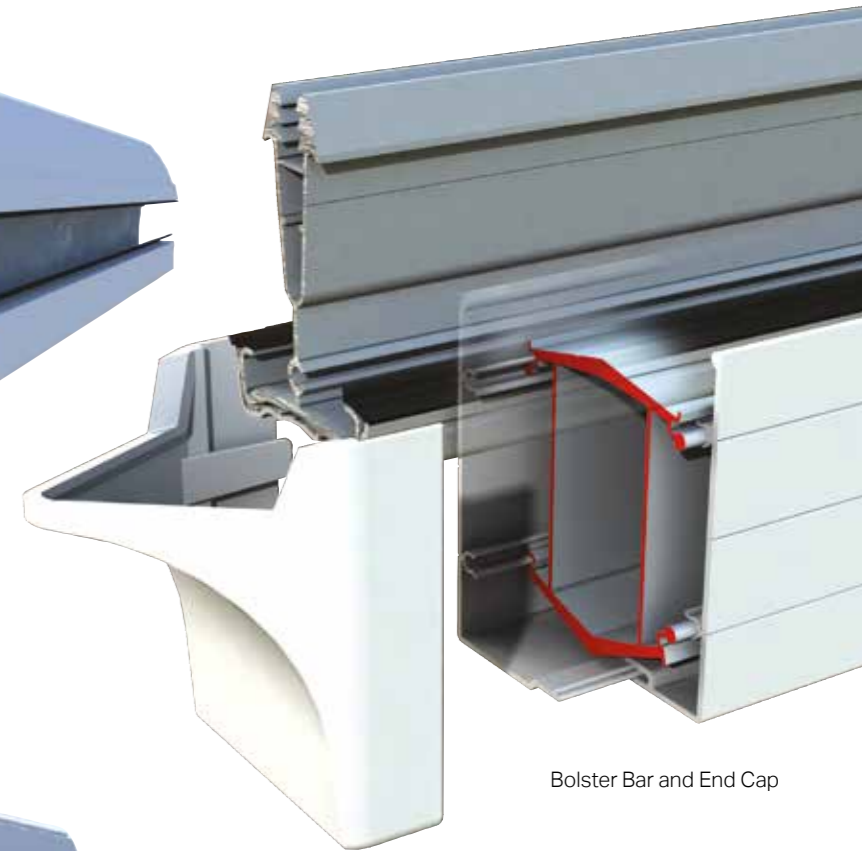
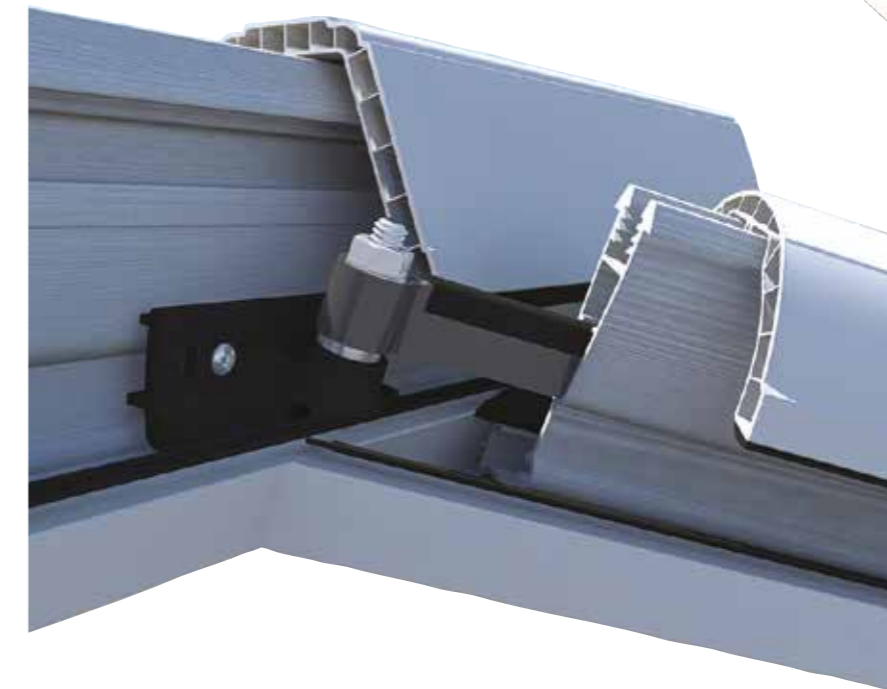

Bolster Bar and End Cap

JACK RAFTER

A key component in the long term performance of a Glass roof. Triple fixing of sleeved tenon provides robust performance. Joint design resists both positive and negative loadings.

INTER - RAFTER

When the roof design calls for a large number of bars to terminate at the ridge, the inter - rafter is the solution.

The inter-rafter is a glazing bar that terminates shy of the ridge end, taking its support from two adjacent bars



THE GLASS ROOF SYSTEM - GLAZING BARS

A natural characteristic of a roof consisting of an aluminium core with PVCu top caps is that these materials expand and contract by differing amounts. The anchor clip controls the point at which movement occurs to maintain the critical weather tight seal at the upslope (ridge) end to move at the bottom of the roof, in the gutter zone.

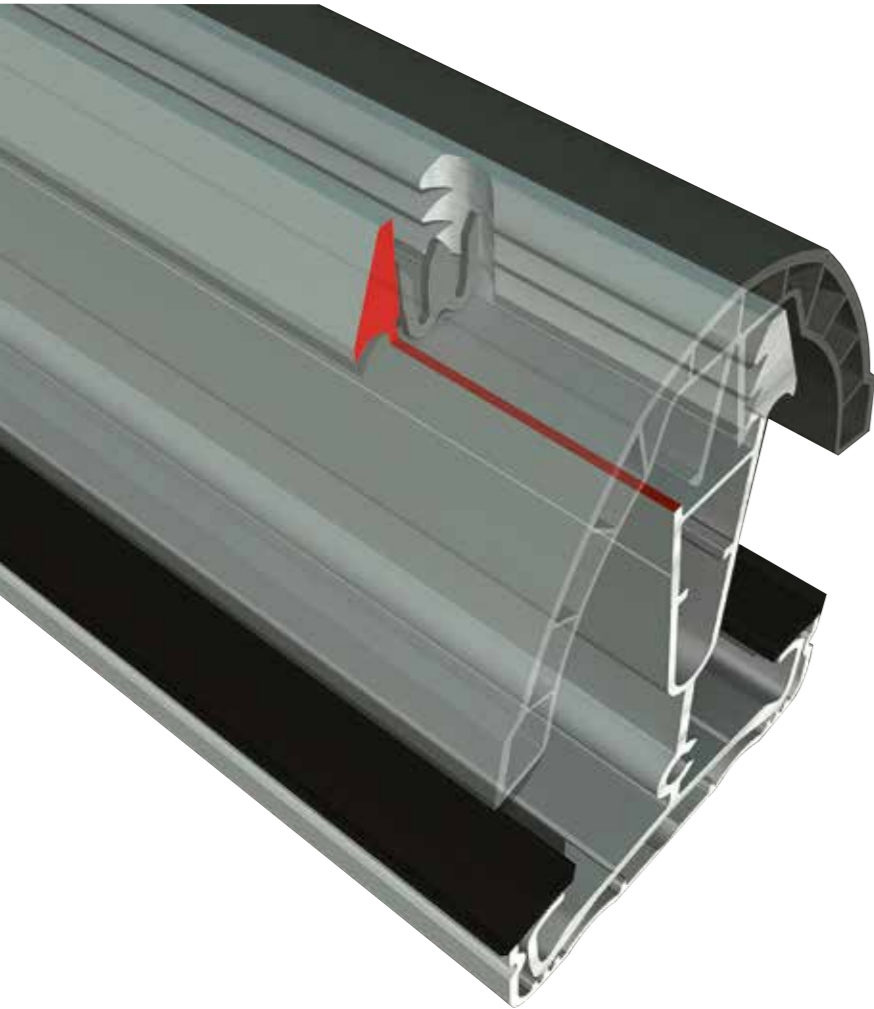

Whilst all roofing systems have this issue, Ultraframe are the only company to provide its customers with a tried, tested and patented solution to give long term peace of mind.

The Anchor Clip can be used with all of Ultraframe's suites of PVCu top caps.

ANCHOR CLIP SPECIFICATION

Anchor Clips are specified as standard and work in tandem with Ultraframe's existing product technology. Glazing bars are prepped at the ridge end of the slope by the factory insertion of a hole through the teeth in the aluminium bar into which is inserted a clip. The anchor clip grabs the barbs of the PVCu top cap. Jack rafters are also fitted with anchor clips.

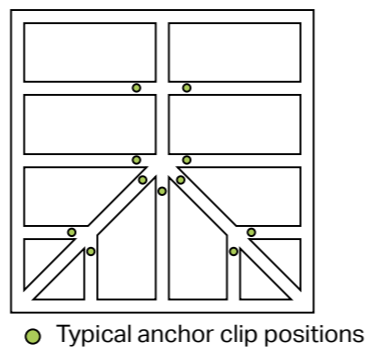
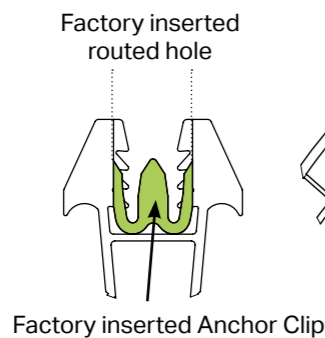

THE GLASS ROOF SYSTEM - GLAZING BARS

TIE BARS

Structurally, tie bars are required to resist downward forces like snow - they prevent the ridge deflecting and the frames rolling outwards. If specified on a conservatory, they **must** be fitted.

There are two main types of tie bar, 3 way and 5 way. In some situations, one of this type of tie bar can be substituted by the Tie Bar Replacement Kit (TBRK*) - see p19.

Some designs feature 'Y' shaped tie bars - see below right.



GLAZING RETENTION CLIPS

Whether polycarbonate or 24mm sealed units, retention clips are automatically specified to ensure that the chance of glazing panel slip is eliminated.



THE GLASS ROOF SYSTEM - STANDARD EAVES

The standard eaves beam for the Glass roof system is a high strength one piece aluminium extrusion. It can accommodate pitches between 5° - 45°. See page 15 for a super duty version and page 16 for a version that can be used between 2½° - 5° pitch.

Illustrated with Classic gutter, which is fitted as standard above 5°



CURVED CORNICE

The Ultraframe Glass roof Aluminium suite is the only aluminium suite on the market which offers a decorative aluminium Cornice option using the existing gutter as a hidden 'liner'. Cornice includes a die cast 135 and 90 degree corner cover and straight jointers, which will help fitters achieve a consistent fit and finish at critical junctions.

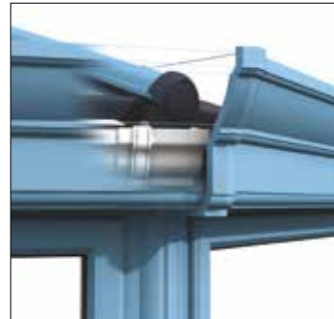

SPECIFICATION

The system can be used with window frames sizes starting from 58mm and the frames can be timber, aluminium or PVCu.

To clad off the aluminium eaves beam a standard 'V' groove fascia which provides clean and simple lines - or upgrade to the Ultraselect fascia and choose from a decorative insert (white only) - see below.

The Glass roof system uses an 'ogee' profiled gutter along with proprietary clip fit gutter/eaves brackets. Square or round rain water down pipes can be chosen.

For those who want the ultimate in aesthetic options, the aluminium Cornice is available and hides the PVCu gutter and glazing bar end caps.



A special eaves beam is specified on lantern roofs or when requested, for timber kerbed roof lights / atriums.

FASCIA BOARD OPTIONS

Standard



Standard default fascia on built up Glass Roofs - White, woodgrain and foils (includes standard colours e.g. grey, cream).

Optional upgrades



SFI003 Tapestry insert is only available in white & deepplac.

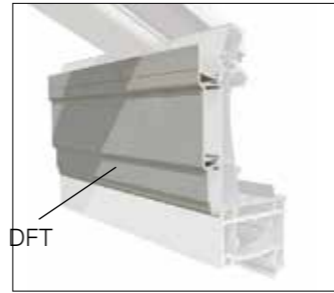

The DFT one piece fascia is available in white and woodgrains.

THE GLASS ROOF SYSTEM - BI FOLD SUPPORT BEAM & EAVES SUPER BOLSTER

- Bi-fold support beam which mounts to the underside of the eaves.
- Eaves super bolster which mounts to the inside of the eaves beam.
- The bi-fold support beam and eaves super bolster profiles can be used separately to bolster the eaves or combined to further increase the spanning capability.
- The bolster sections only need to be specified on the elevation where the larger opening is required.
- The bi-fold support beam is 70mm tall and runs between corner posts.
- The eaves super bolster support beam is 134mm tall.
- PVCu claddings on internal and external fascia.

On the elevations which do not require the spanning capability, either the frame height can be adjusted, or a standard frame add on or corner post profile can be used to pack the frames under the eaves.

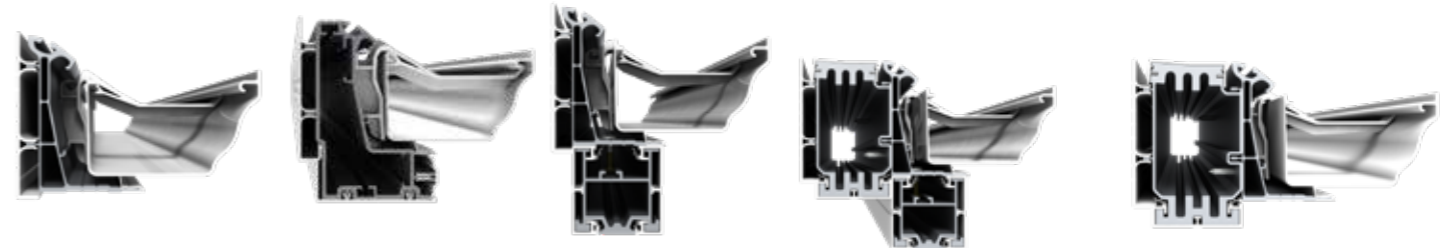

Standard Eaves Super Duty Eaves Bi-fold Support Beam Combined Bolstered Eaves Eaves Super Bolster

THE GLASS ROOF SYSTEM - SUPER DUTY EAVES

The Super Duty Eaves Beam should be specified where additional spanning performance is needed, allowing confident specification of folding/sliding doors (or indeed any type of opening such as in-line sliders).

Cross Sectional Profile



TECHNICAL SPECIFICATION SUPER DUTY EAVES BEAM

- Structural 'beefier' aluminium profile that uses existing PVCu components to clad and cap for optimum performance
- Sits 38mm taller than the standard eaves beam (remember this when calculating overall ridge heights).
- Needs to be specified all the way round the nominated conservatory and NOT simply on the facet into which the doors are to be fitted.
- Readily interfaces with box gutters and Gable Support Beam, to offer maximum integration and configurability
- Ultraframe's span charts need to be studied carefully BEFORE conservatory selling and design starts... the elevation into which the doors are to be fitted, the style of conservatory and the 'span onto' dimension all affect the maximum allowable width of opening when using the Super Duty Eaves Beam.
- If a conservatory design requires an opening width greater than that which can be offered with the Super Duty Eaves beam, then consider bi fold support eaves or super bolster eaves or both combined. If greater a portal/goalpost arrangement will be needed - Ultraframe can provide a custom solution.

Eaves beam charts - Refer to page 30 of Glass Surveyors Guide for spanning performance.

If the loading conditions are more onerous than the Super Duty Eaves Beam can cater for, a goalpost arrangement will be required.

Goalpost by Ultraframe

- Aluminium header beam and leg post
- Lightweight for fast and easy installation
- Sits behind the eaves beam for a minimalist look
- Internal pelmet option available
- Easy to order with your Ultraframe roof

Footplates

Welded footplate supplied as standard. Base plates are provided with 4 pre-drilled holes for bolting down and 4 pre-drilled holes for fixing to the post. The post can be fixed centrally or at the corner on site.

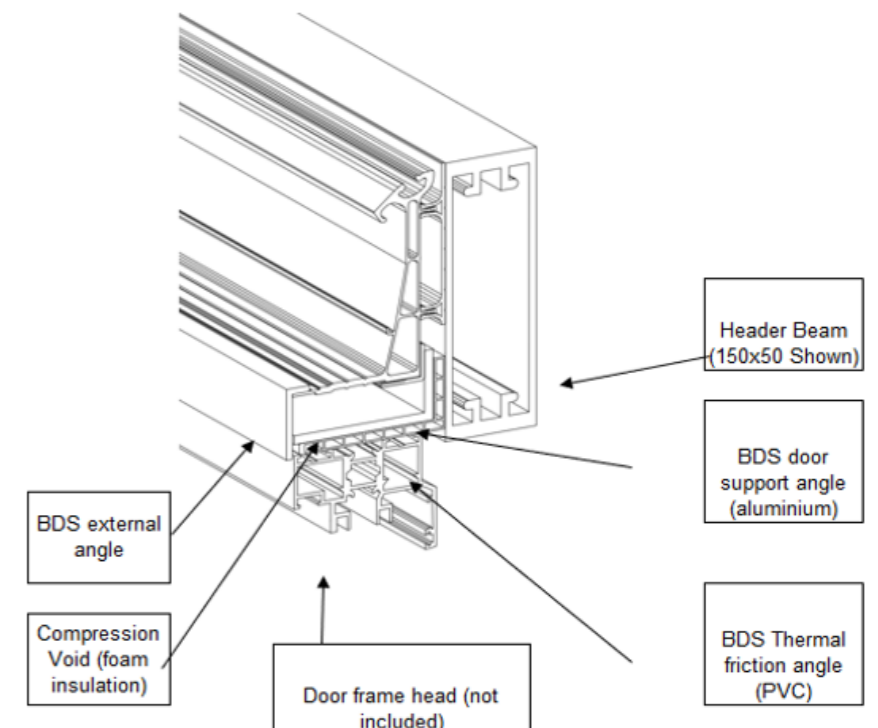
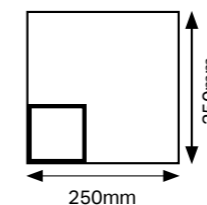

Choosing the right Goalpost for large door spans

If the large door span is parallel to the ridge please use chart A and if it is perpendicular to the ridge, please use chart B.



Chart A

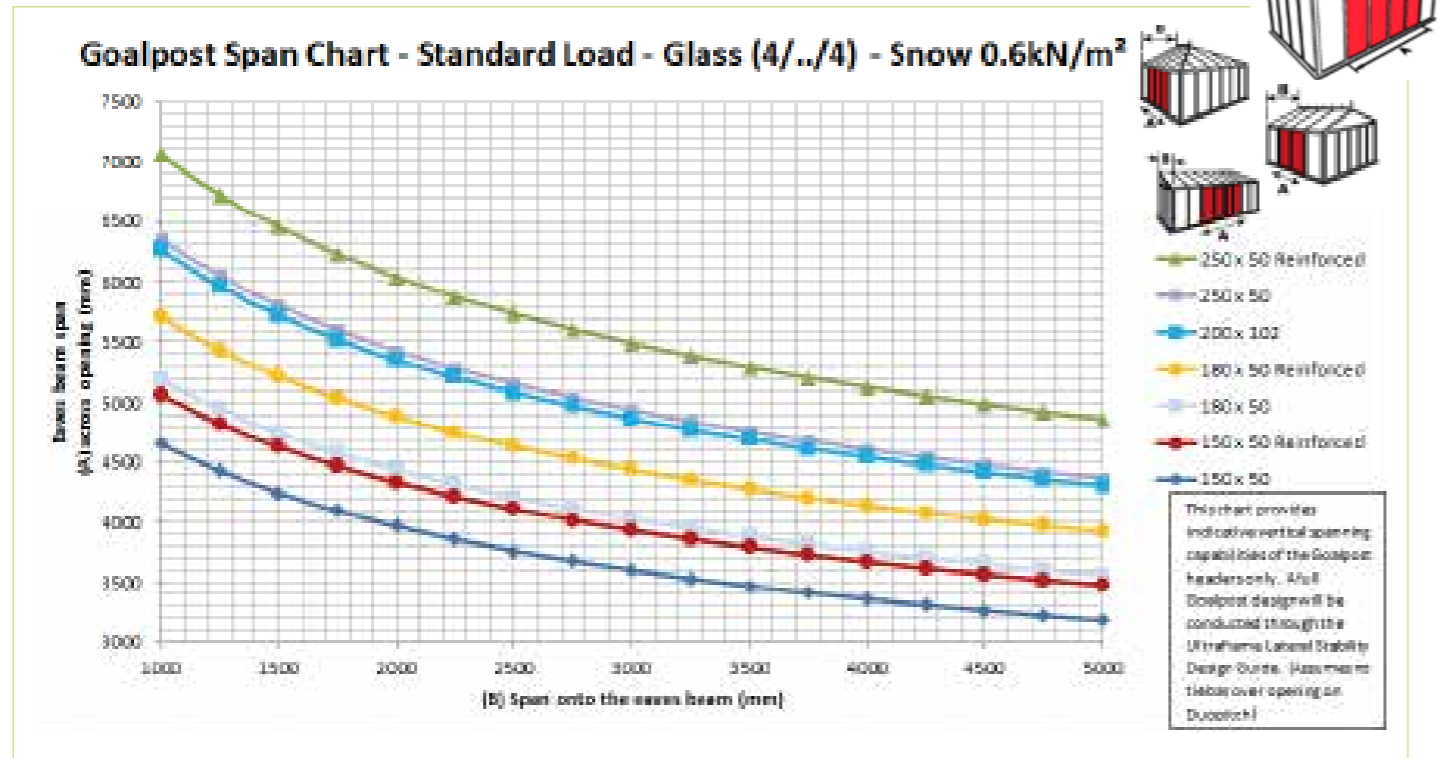

Chart A

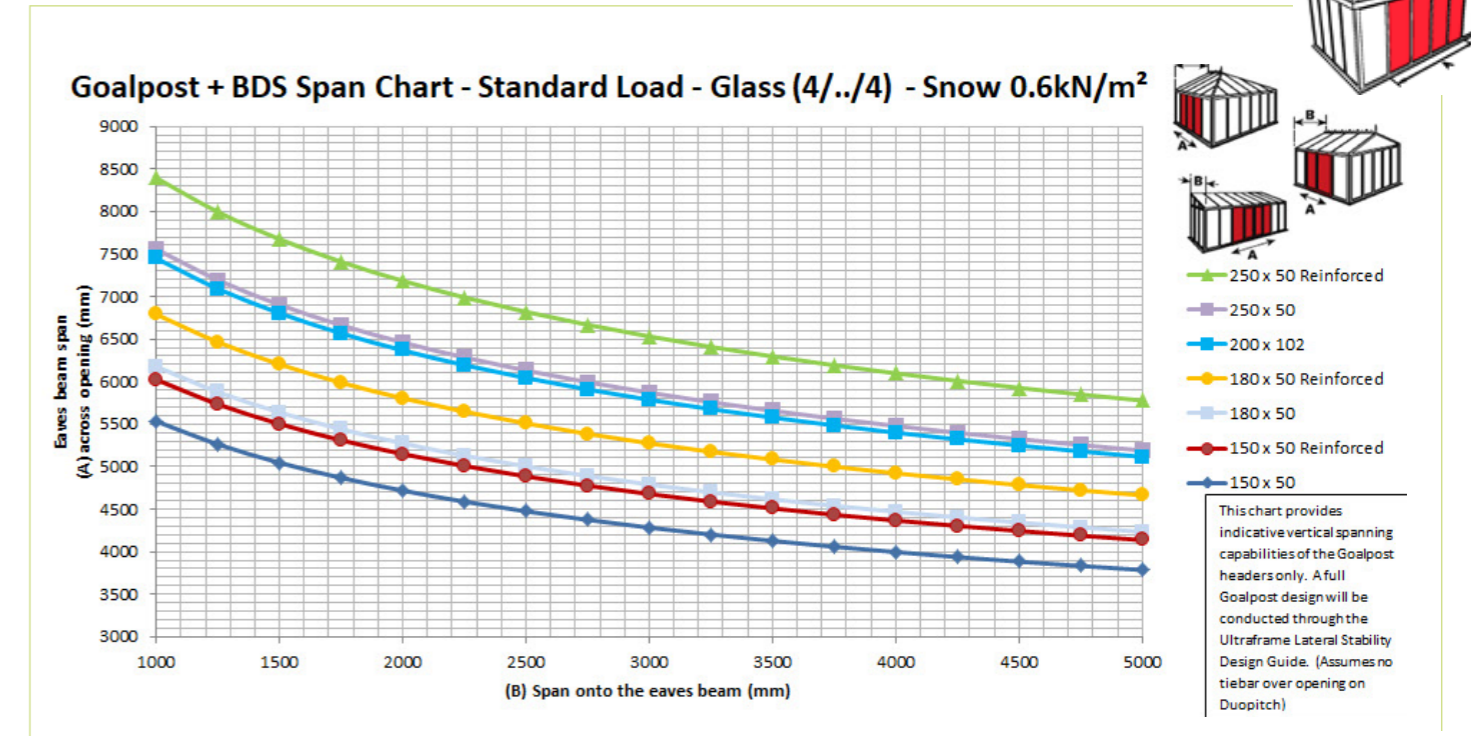

Chart B

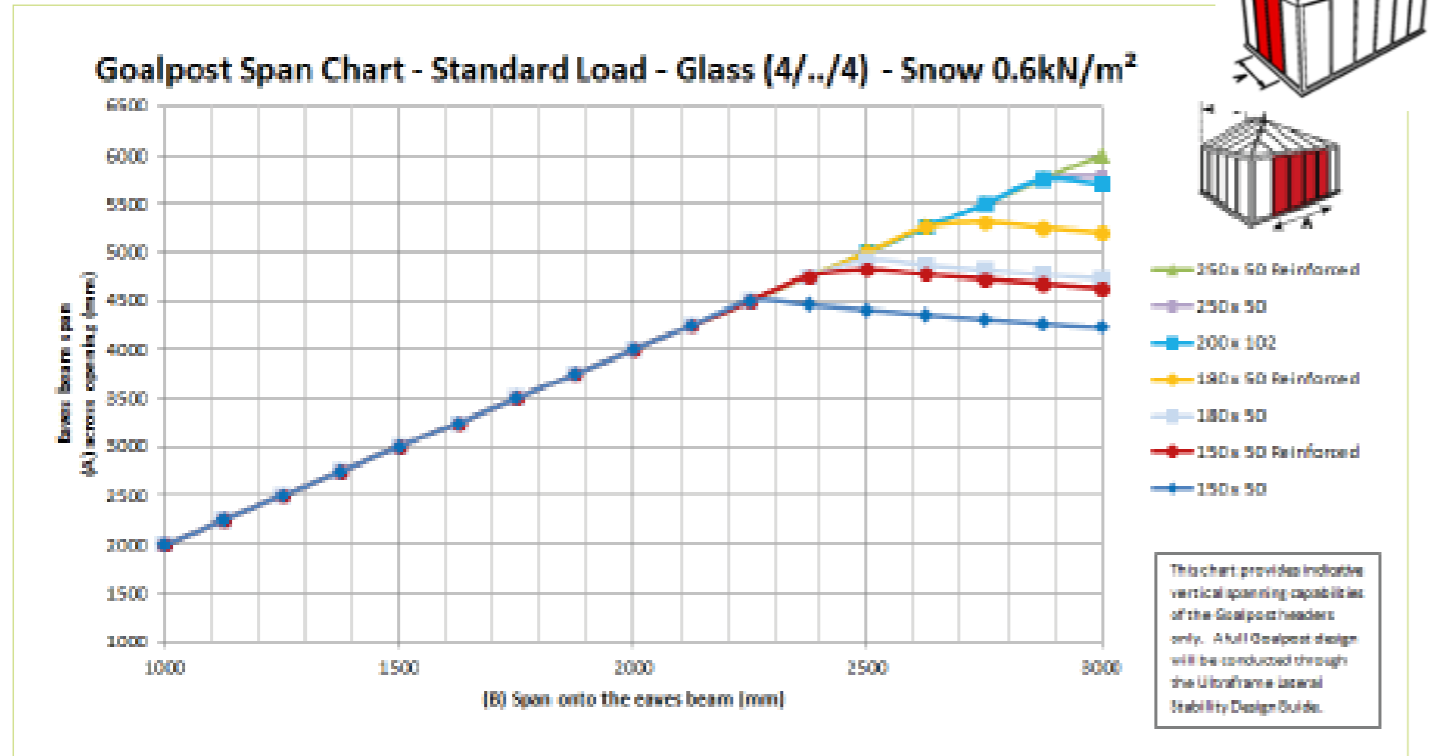
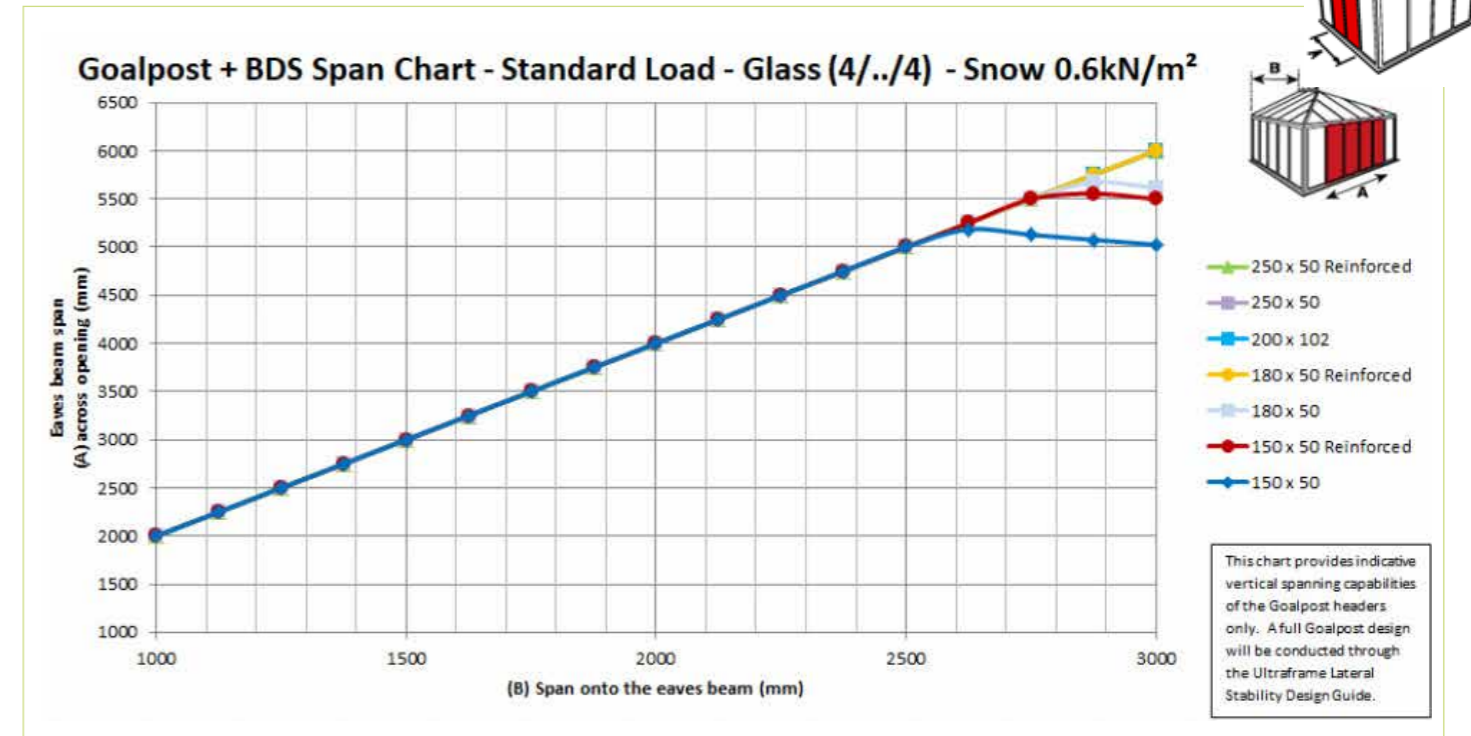

Chart B



These span charts provide indicative vertical spanning capabilities of the Goalpost header beams only. A full Goalpost design will be conducted through the Ultraframe Lateral Stability Design Guide. They assume that there is no tie bar over an opening on Duopitch roofs.

CHOOSING THE RIGHT BEAM FOR LARGE DOOR SPANS

If you decide to use large door spans in your building design, you can determine which Ultraframe eaves beam reinforcement you require using the span charts below.

Eaves beam reinforcements can be used with both Glass Roofs and Livinroofs, but the loads of each system is different. Use either the Glass Roof or the Livinroof charts.

Standard Eaves and Super-duty Eaves are different eaves beam systems that need to be used on all elevations, however the Bi-fold Support Beam (BFS), Eaves Super Bolster (ESB), Combined Bolstered Eaves (CBE) and Goalposts are added to Standard Eaves and therefore are only needed on the elevation with the large span.



Chart A

Glass Roof Eaves Span Chart - Standard Load - Glass (4/././4) - Snow 0.6kN/m²

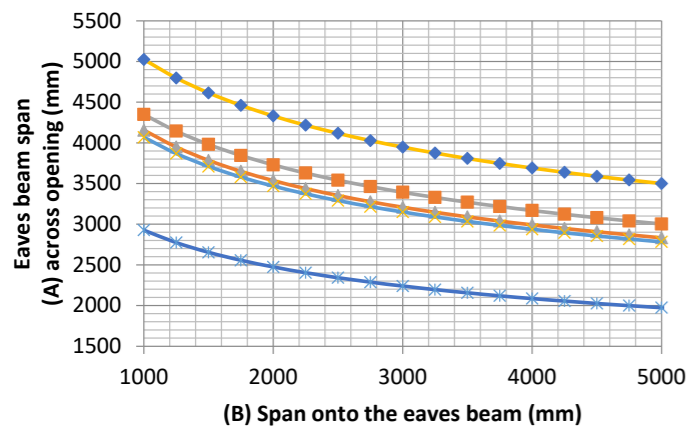

- ◆ Combined Bolstered Eaves (CBE)
- Eaves Super Bolster (ESB)
- ▲ Bi-fold Support Beam (BFS)
- ✕ Super-duty Eaves
- ★ Standard Eaves

Opening span performance
Doors into the front elevation of a Victorian/ Georgian/ Gable style conservatory

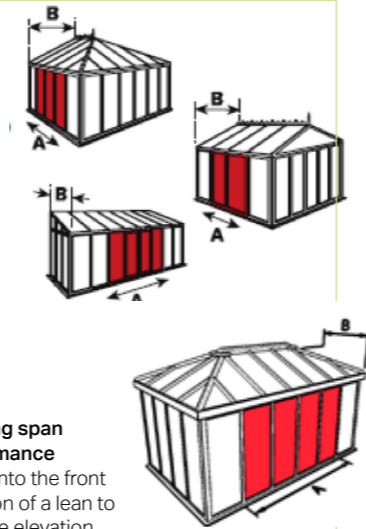
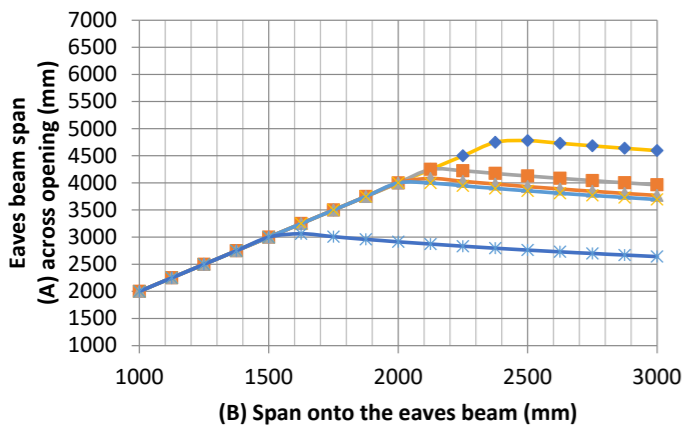

Chart B

Glass Roof Eaves Span Chart - Standard Load - Glass (4/././4) - Snow 0.6kN/m²



- ◆ Combined Bolstered Eaves (CBE)
- Eaves Super Bolster (ESB)
- ▲ Bi-fold Support Beam (BFS)
- ✕ Super-duty Eaves
- ★ Standard Eaves

Opening span performance
Doors into the front elevation of a Georgian style conservatory with hip bars

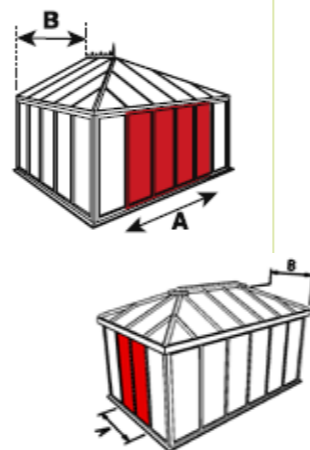

Disclaimer: Please note these span charts only indicate which eaves beam reinforcement is required to manage the downward deflection and load on the doors. They do not take into account any information about the building structure and its ability to withstand any lateral forces. Please refer to page 3 regarding structural support for lateral forces.

THE GLASS ROOF SYSTEM - LOW PITCH EAVES

if the Glass roof is required between 2.5° - 5° pitch, then in place of the standard eaves beam it uses one that sits lower. It features a simple 'flowline' gutter too in place of the standard 'ogee' gutter.

TECHNICAL SPECIFICATION LOW PITCH EAVES BEAM

- For use between 2.5° to 5° - can be specified up to 10°
- Structural firrings at 2.5° and 5° are available
- Suitable for raked frames too



THESE ITEMS RELATE SPECIFICALLY TO THE LOW PITCH GLASS ROOF:

STRUCTURAL FIRTINGS

Ultraframe have gone one step further with these ready assembled interlocking profiles that not only fill the 'hole' between the side frames and the roof but which add substantial support to the whole structure particularly when doors are in the end elevations.

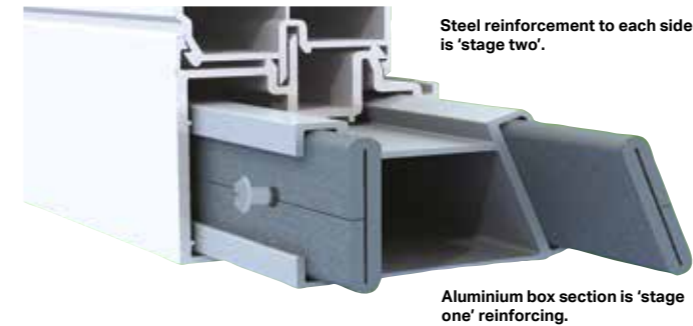

- Available at 2.5° and 5° pitch in 3045mm and 4045mm lengths - these need to be cut to length on site.*
- The firrings consist of a series of inter connected/locking PVCu profiles that are supplied pre-fabricated.
- Firrings are supplied in different 'conditions' to suit various projections and applications.
- The 'flowline' guttering can be clipped to the furring allowing the guttering to run along the front and sides of the conservatory. This can save the need for a soakaway as the guttering can be routed back to the house and rain water dispersed down the dwelling's existing fall pipes.

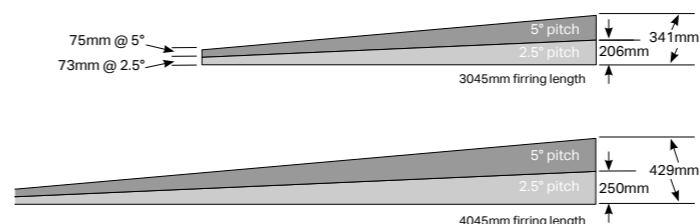

BOX GUTTER SPECIFICATION

When there is insufficient height under the bungalow soffit it may necessary to utilise a box gutter with an extended leg and flange to gain extra height.

In these situations, the box gutter MUST be supported by brick piers or gallows brackets.

Always speak to the Ultraframe Technical Support Team about the correct design/specification in this area - the box gutter and structural gallows bracket are priced on a project by project basis.



BOX GUTTERS

When a conservatory roof slopes backwards towards the existing building a box gutter is required. Ultraframe offers a choice of three main options:- 165mm standard, 265mm standard or custom design. The latter option is used when the design is particularly bespoke, with Ultraframe using every ounce of its design and fabrication expertise.

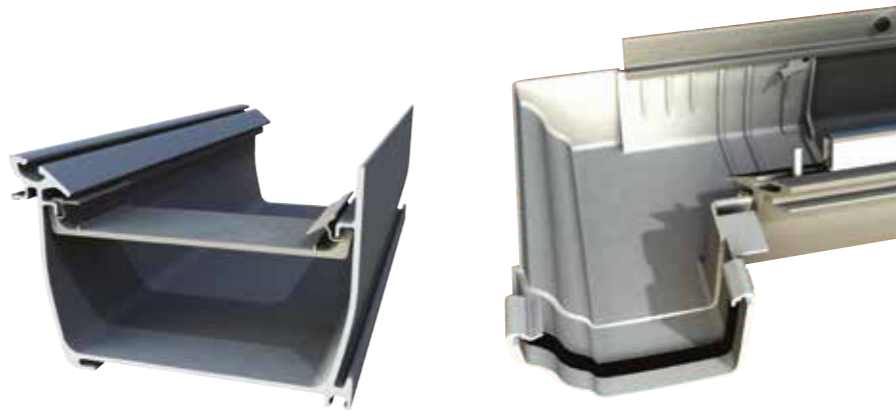

Gutter Strap Assembly

Box gutter adaptor which comes with a measured 'shot' of Gutterbond sealant



Box gutter with 'V' Groove Fascia



Raised Back box gutter - custom design



Box gutter with Ultraselect Fascia into which can be fitted SF1003 white infill



Top: 165mm Standard. Above: 265mm Standard

Chambered box gutter - 165mm only

IMPORTANT:
The standard or chambered box gutter is 165mm wide (for use when collecting from a single roof). The 265mm wide box gutter is used to give extra capacity when collecting from two roofs eg. bungalow situations etc.

SUPPORT SPECIFICATION

It is vital when box gutters are specified that - even at sales stage - the issue of providing adequate support is considered. Attachment to timber fascias alone is NOT sufficient and brick piers, gallows brackets and other hangers must be considered.

All of Ultraframe's box gutters are insulated to minimise condensation risk. Where box gutters are jointed, they are sleeved and bolted. Injection moulded adaptors are used to ensure

seamless and watertight jointing between the PVCu gutter and the aluminium box gutter.

Each adaptor comes complete with its own dry jointing gasket and measured 'shot' of Gutterbond proprietary sealant to ensure rapid completion even in the inclement weather typically found in the U.K.



Custom gallows brackets also available.



Gallows Bracket - off the shelf. Suitable for 165 or 265 box gutters.



Hanger Bracket - alternative support for 165 box gutters.

OTHER ITEMS - STRUCTURAL

GABLE SUPPORT BEAM

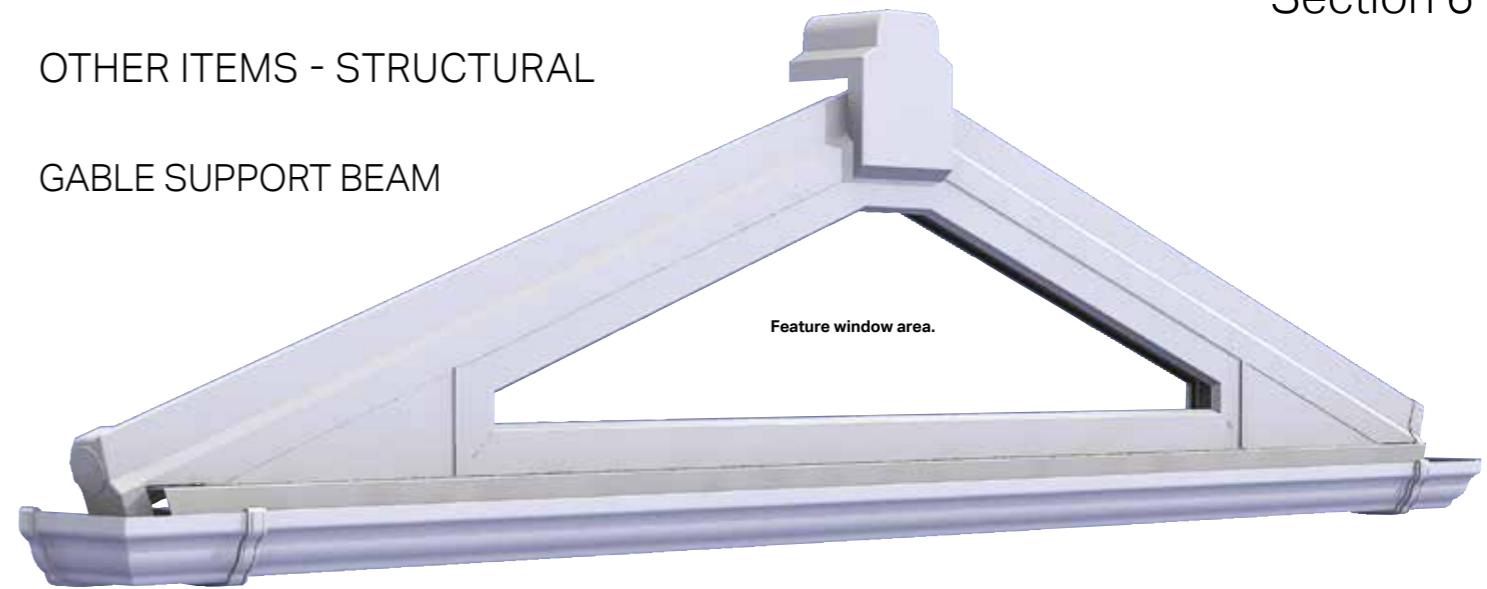

The Gable conservatory is ever more popular as it has a square front to maximise floor space for the homeowner whilst it has an interesting large infill window, into which feature designs like 'sunbursts' can be installed.

When doors are placed beneath a gable frame, additional structural support is needed to ensure frame wobble/deflection is eliminated.

The Ultraframe Gable Support beam interfaces with the standard Eaves Beam to create one holistic structural 'collar'. It comes complete with 'cheese wedge' infills to ensure neat detailing.

Ultraframe strongly recommends this upgrade option to be used on gable designs.

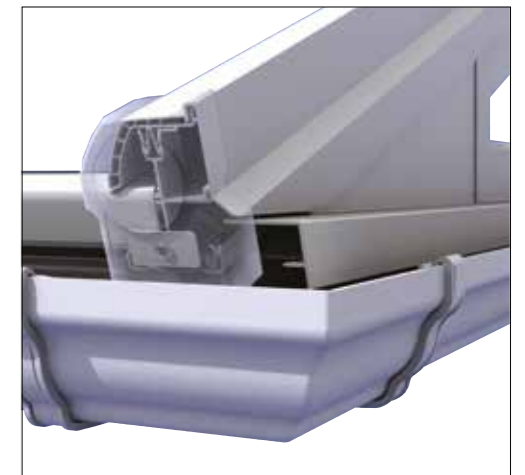
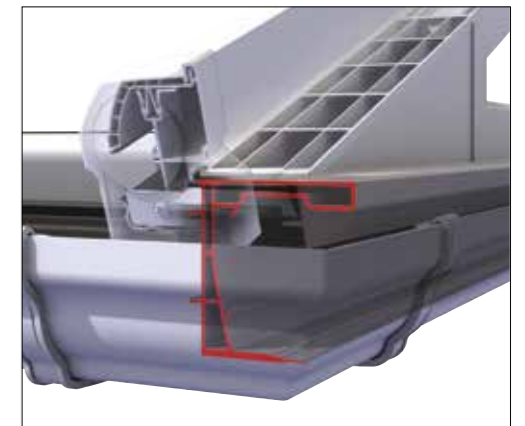

OTHER ITEMS - STRUCTURAL

TIE BAR REPLACEMENT KIT (TBRK)

The Tie Bar Replacement Kit (TBRK) is the UK's only effective solution to traditional tie bars. Tie bars have been an essential part of a conservatory installation since Victorian times and conservatory designers and installers are well versed in their fitment and fine-tuning.

The TBRK features new state-of-the-art technology. To replace a tie bar* (some larger conservatory designs feature more than one tie bar - TBRK can only ever replace one) five special product measures are additionally specified by Ultraframe at the time of ordering.

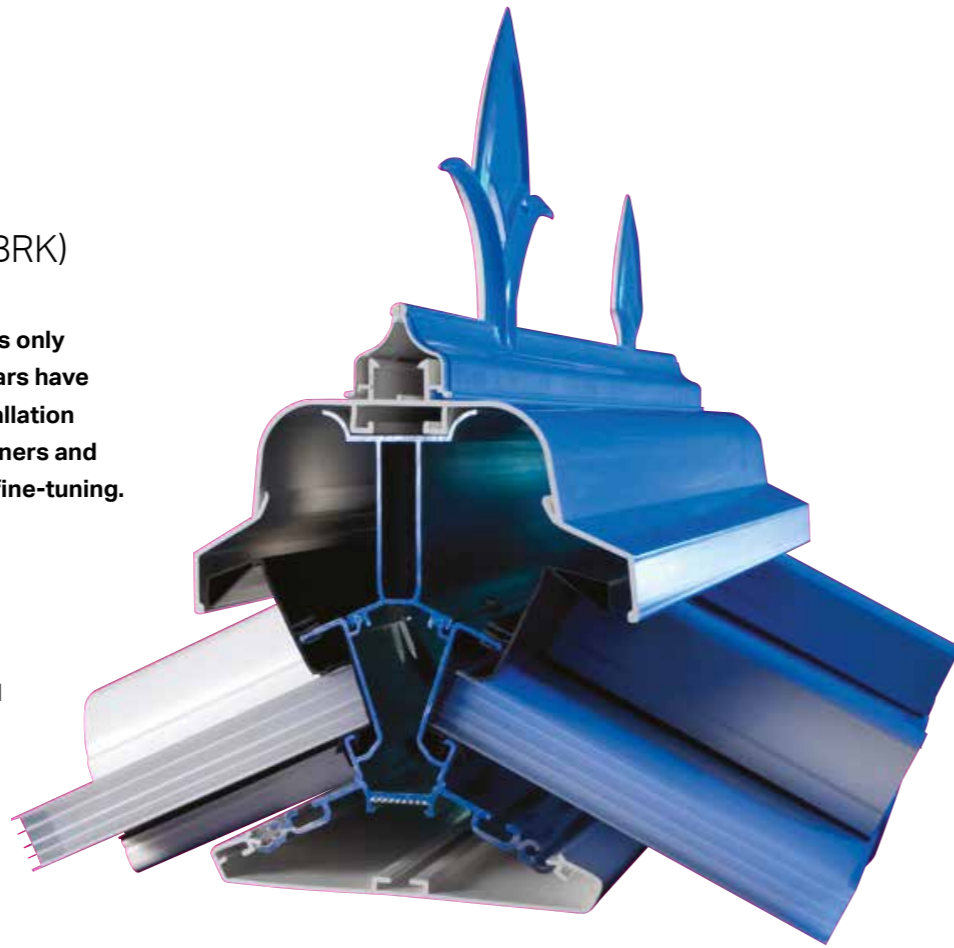

1 An aluminium bolster beam extends along the entire length of the ridge and acts as one with the existing aluminium ridge body to virtually eliminate deflection.



2 Cast aluminium 'end stop' on the eaves beam featuring integral slots for two anchor bolts to hold the conservatory to the host wall even more securely.

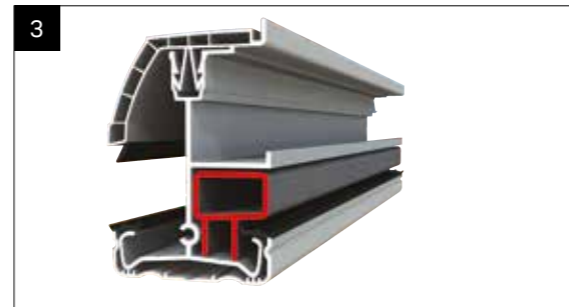

3 This short piece of reinforcement in each starter bar ensures that three anchor bolts are drilled into the host wall, when the reinforcement prevents the aluminium bar being crushed under excessive torque. It also ensures that additional reinforcement is offered where the bar intersects the eaves beam.



4 A 'Ridge Compression Plate' sits at the end of the aluminium ridge body where it joins the house wall - this distributes compression forces across the host wall and allows installers to assemble and suspend the starter bars prior to attaching the main ridge body.



5 An additional cleat is inserted in the eaves beam corners (making two cleats in total) whilst this is backed up by a further butterfly cleat (illustrated).

*TBRK cannot replace tie bars in these situations - gable fronted designs 'Y' shaped tie bars - where they terminate on valleys.



Valleys can be designed / used in the following ways:

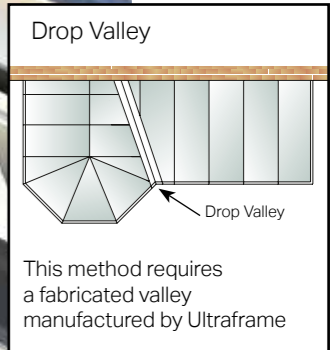
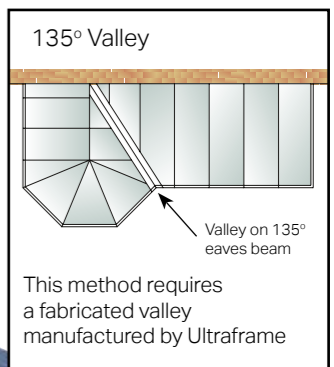
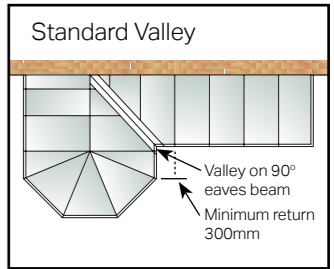

The Valley is a heavy weight structural component that drains two adjacent glazed roof slopes and connects to the eaves beam and the ridge/half ridge.

When glazing bars connect to the valley they use sleeved tenons to create strong joints - construction detail is the same as the jack rafter on p11.

Triple fixing of sleeved tenon provides robust performance. Joint design resists both positive and negative loadings.



OTHER ITEMS - VENTILATION

It is vital to the maintenance of a comfortable environment - ventilation is often overlooked by both consumers and manufacturers, but not Ultraframe, who are still the only conservatory roof brand to offer in built trickle ventilation as standard.

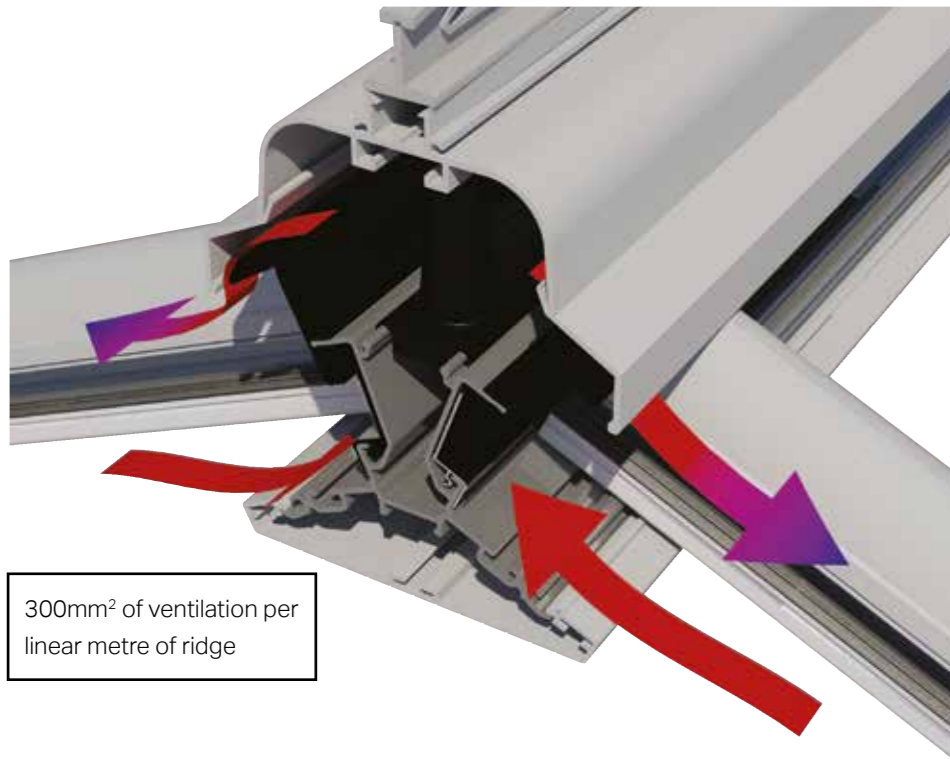

TRICKLE VENTILATION SYSTEM IN THE RIDGE

Harnesses natural upward movement of warm air to carry stale, moist air to the roof apex for venting outside. This is standard in all duo pitch (Victorian, Georgian, Gable etc) Glass roofs. A version of this feature is included in the wallplate in lean to designs.

EAVESFLOW

This is an upgrade option (but highly recommend on all roofs that don't feature our internal insulated pelmet. Eavesflow sits within the eaves beam, introducing clean fresh air to replace the warm moist air that exits through the ridge. (Eavesflow can be specified with the non-ventilated wallplate as an upgrade option.)

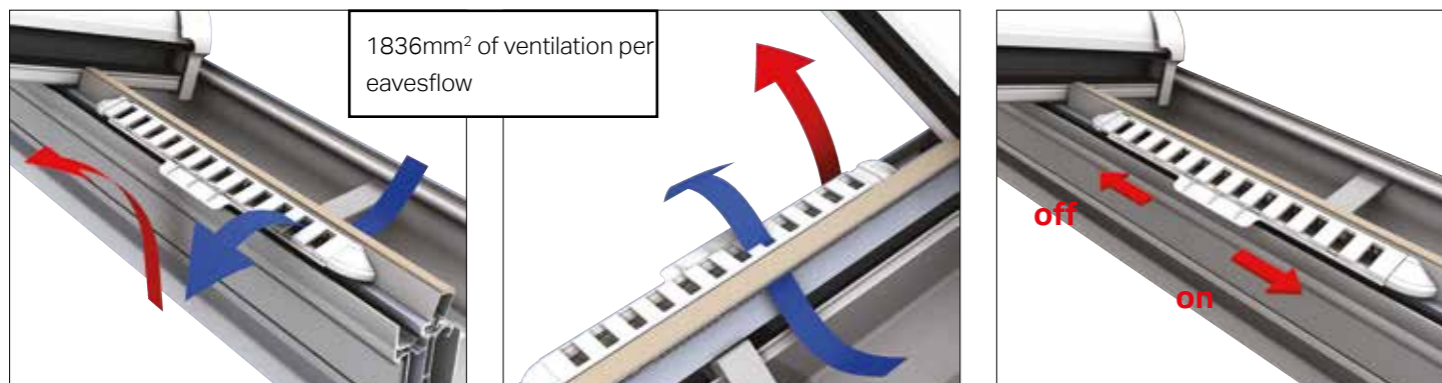

- The glazing support trim is punched and into this clips Eavesflow ventilation to provide an additional source of fresh air and complements the unique built-in ridge or wallplate ventilation system with slider controller for on/off regulation.

OPENING ROOF VENTS

Roof vents can be specified with a pole operated screw jack mechanism or you can opt for a full climate control package of rain sensor and thermostat.

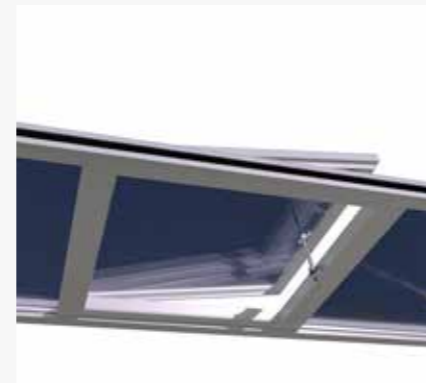

Pole operated screw jack mechanism

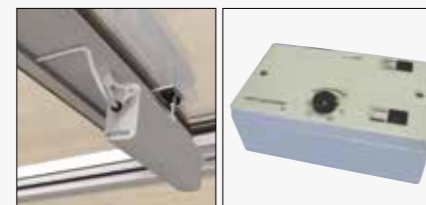

A climate control package is available to automate the roof vent.

OTHER ITEMS - CONSERVAFLASH

Conservaflash™ is a pre-formed PVCu flashing system that will change the way you install.

Conservaflash™ is an engineered product offering professional results - in a flash! It is also covered within Ultraframe's BBA Certificate. Conservaflash™ can be specified when a roof is ordered and a pre-configured flashing pack will be delivered with the roof. Ultraframe Conservaflash™ can be specified when the host wall is of brick construction.

SPECIFICATION

- Conservaflash™ is manufactured from PVCu and comprises:
- Extruded soaker that is pre-clipped into the starter bar.
 - Stepped flashings, incorporating weather bars, for 5 different pitch ranges
 - Universal horizontal flashing for lean-to's and aprons on duo-pitch roofs.

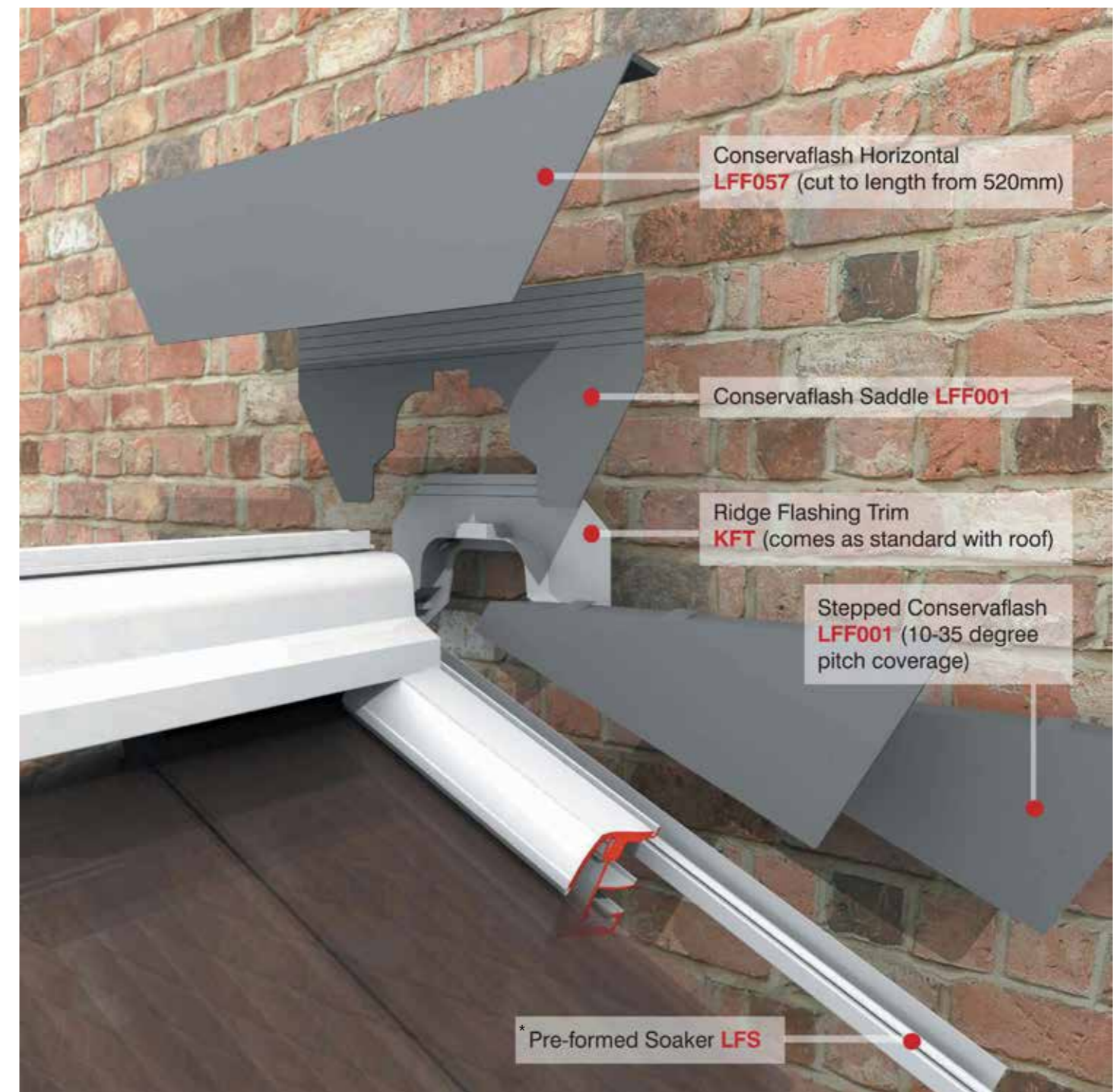

*Can be ordered on its own or with a roof

FEATURES & BENEFITS

- Save money when compared to buying lead.
- Save at least an hour on each installation.
- An engineered solution - each and every time.
- No waste - precise amount supplied.
- Comes with the roof - an integrated solution.
- Convenient, pre-packed with no environmental risks.
- Suitable for duo pitch and lean to 'gable to gable' designs.

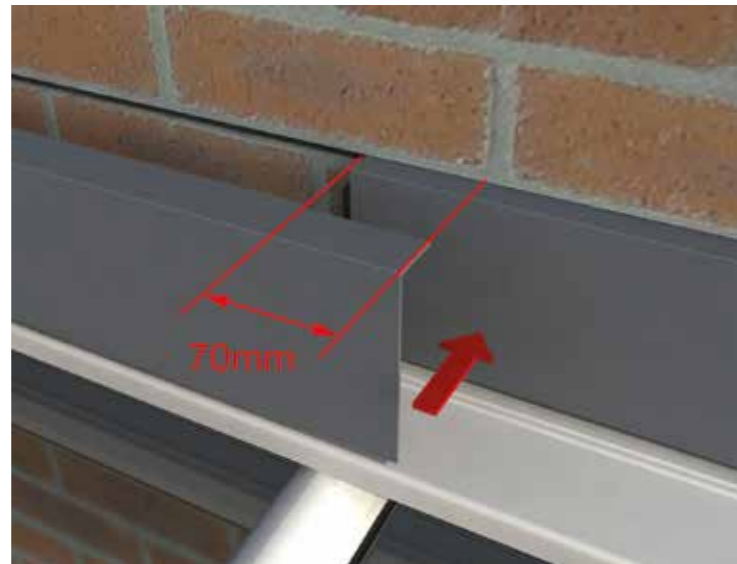

Lean-to installation

INSTALLATION OVERVIEW

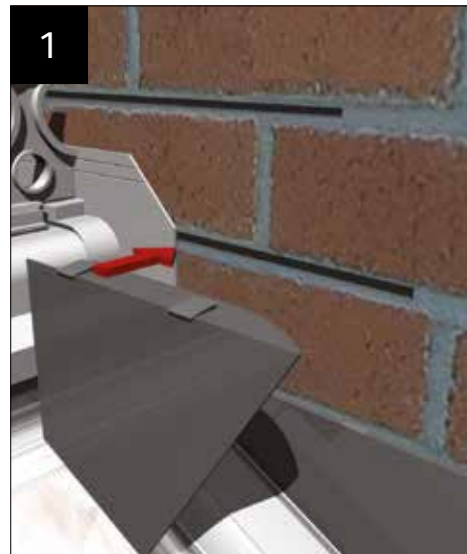

1 Apply 2 beads of silicone to integral weather-bars - insert into 35mm slot.

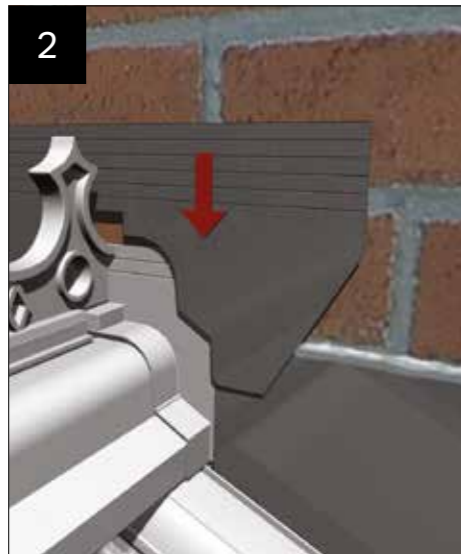

2 'Butter' with silicone and fit pre-cut saddle trim.

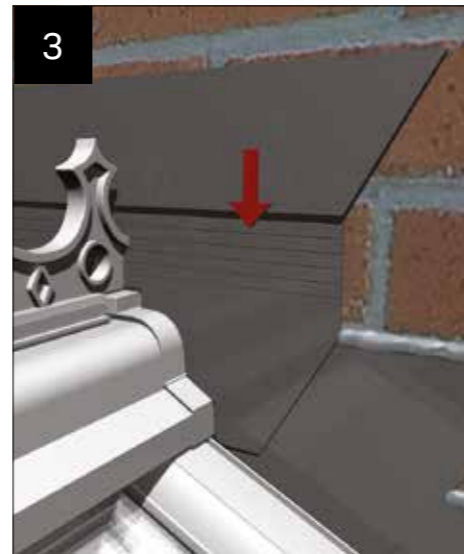

3 Offer up the horizontal flashing and cut ends as appropriate.

HORIZONTAL FLASHING OPTIONS

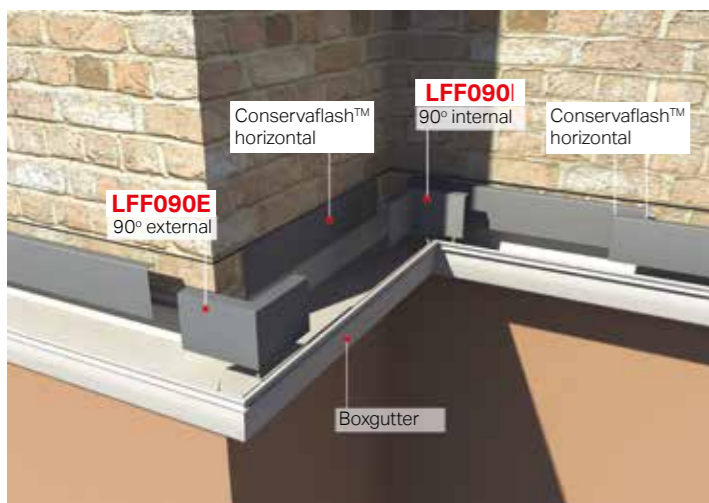

90° external/internal corners for boxgutters

GLAZING

When designing your conservatory, the choice of a glass or polycarbonate roof is an important one. To enable you to use your conservatory all year round, you need a glazing material that deflects heat from the sun in the Summer and retains the warmth from heating appliances in the Winter. You may also want a material that allows maximum light into your home.

ULTRAFRAME POLYCARBONATE

Available in a wide range of specifications, colours and thicknesses, to suit your budget, your chosen conservatory colour and the position and orientation of the conservatory, polycarbonate is a lower cost alternative to glass and it can be treated to offer excellent solar protection and thermal properties, but this is at the cost of light transmission.

PROPERTIES

Polycarbonate is a very popular glazing material for conservatory roofs as it is lightweight, durable and exceptionally strong – up to 200 times stronger than glass and virtually shatterproof. All polycarbonates work to lessen the glare and heat from the sun to ensure that your conservatory can be as comfortable as possible all year round.

The standard range of polycarbonate thicknesses is 25mm or 35mm, with a colour choice of clear, bronze, opal, bronze/opal and solarguard. All are designed to reduce glare and minimise solar heat gain. Bronze/Opal gives a bright internal appearance even on a dull day, reduces solar heat gain and provides privacy. Solarguard limits the potential for heat build-up within the conservatory, whilst allowing light to enter the roof, deflecting solar radiation and reducing solar heat gain by up to 50%, when compared with conventional polycarbonates.

BENEFITS OF THE RANGE

- Testing to Class 1 Spread of Flame Protection
- 10 year warranty for light transmission & breakage
- Superb thermal efficiency and strength due to the multi-wall construction

DETAILS - Common to polycarbonate and sealed units



PVCu Muntin Bar - joins long sealed units together

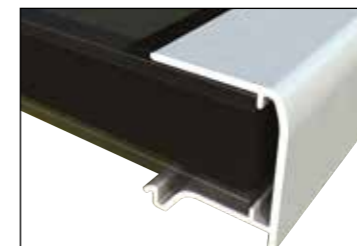

PVCu End Closure Detail - creates additional protection at the gutter end of the glazing panel

COLOUR OPTIONS

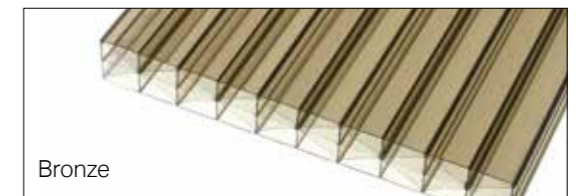

Glazing Material Retention Clips - See page 13 for further information
Sealed Units or Polycarbonate

GLAZING PERFORMANCE

Ultraframe offer a range of glazing options to be used with our roofing systems. These includes both the Celsius and Conservaglass glazing brands. Ordering from Ultraframe is simple and easy, reducing the number suppliers as well as providing you with specialist support in choosing and providing your glazing requirements.

Conservaglass Range

- True self cleaning.
- Keep out up to 86% of the sun's heat energy.
- U-Values of 1.0 or 1.2.
- Warm edge spacer
- All units are 4-16-4 toughened, argon gas filled and come with black warm edge spacer as standard.
- Up to 3.59m long units in tier 1 blue and neutral (see table below), max length other specs is 3200mm.

Celsius Range

- Premium brand name
- Superior UV ray protection up to 94%
- EasyClean technology ensuring glass require much less maintenance
- Can provide U-Value as low as 0.9
- Light transmission as high as 61%
- Argon filled units to increase insulation as well as reduce overall rain and traffic noise

	Tier 4		Tier 3		Tier 2					Tier 1			
	Celsius Elite	Ultra86 Blue	Celsius One	Ultimate Blue	Celsius Clear	Blue 4S	Neutral* 4S	Aqua 4S	Bronze 4S	Std Blue	Std Neutral*	Std Aqua	Std Bronze
U-Value	0.9	1.0	1.0	1.0	1.0	1.0	1.0	1.0	1.0	1.2	1.2	1.2	1.2
Light Transmission	34%	15%	38%	27%	61%	41%	37%	32%	42%	42%	45%	33%	52%
Solar Rejection	83%	86%	83%	80%	58%	67%	65%	78%	66%	60%	60%	72%	51%
UV Protection/Rejection	94%	90%	94%	90%	73%	86%	82%	90%	89%	83%	78%	92%	86%
Toughened to BS EN 12150-1	✓	✓	✓	✓	✓	✓	✓	✓	✓	✓	✓	✓	✓
Manufactured to BE EN 1279-2	✓	✓	✓	✓	✓	✓	✓	✓	✓	✓	✓	✓	✓
10 year guarantee	✓	✓	✓	✓	✓	✓	✓	✓	✓	✓	✓	✓	✓
Cleaning	Self Clean	Self Clean	Self Clean	Self Clean	Self Clean	Self Clean	Self Clean	Self Clean	Self Clean	Self Clean	Self Clean	Self Clean	Self Clean
Cavity Fill	Argon	Argon	Argon	Argon	Argon	Argon	Argon	Argon	Argon	Argon	Argon	Argon	Argon
Warm Edge	✓	✓	✓	✓	✓	✓	✓	✓	✓	✓	✓	✓	✓
24mm* (4-16-4)	✓	✓	✓	✓	✓	✓	✓	✓	✓	✓	✓	✓	✓
Colour tint	Blue	Azure Blue	Blue	Blue	Neutral	Blue	Neutral	Aqua	Bronze	Blue	Neutral	Aqua	Bronze

Please Note: Delivery charges may apply. In order to pass building regulations, all conservatory over 2.5m wide will need a glass U-value of at least 1.2. Smaller conservatories will need glass to be specified with 1.0 U-value. The thermal design guide within UDesign will provide the specific U-Value of each glass roof.

Key
Celsius Glass
Conservaglass

ULTRAFRAME POLYCARBONATE

Polycarbonate Sheet	Light Transmission		Solar Transmission		U Value Wm ² K ⁻¹		Shading Efficiency	
	25mm	35mm	25mm	35mm	25mm	35mm	25mm	35mm
Clear	65%	51%	63%	55%	1.7	1.3	73%	72%
Opal	31%	29%	37%	35%	1.7	1.3	42%	41%
Bronze	24%	11%	26%	14%	1.7	1.3	30%	27%
Bronze / Opal	11%	18%	16%	22%	1.7	1.3	18%	17%
Solarguard	5%	8%	8%	8%	1.7	1.3	9%	9%

Light Transmission - Percentage of light transmitted through the unit / polycarbonate sheet.

Solar Rejection - The proportion of the sun's energy that is rejected. The higher the percentage the better it is.

Solar Transmission - The proportion of the sun's energy that is transmitted through the sheet. The lower the percentage the better it is.

U Value W/m² °K - A measure of how good the material is at preventing heat loss to the outside. The lower the figure, the more thermally efficient it is.

UV Protection - The higher the % the lower the possibility of furniture and fabrics fading.#

Shading Efficiency - The lower the figure the more shade is created.

COLOURS / FINISHES - PVCu ROOFS

Colour applied correctly has a profound positive effect on your wellbeing. It strongly influences how we interact with each other and our surroundings... so do you stick to conventional conservatory colours and finishes or do you choose something different?



Coloured Foil Roofs are available in the following colours:

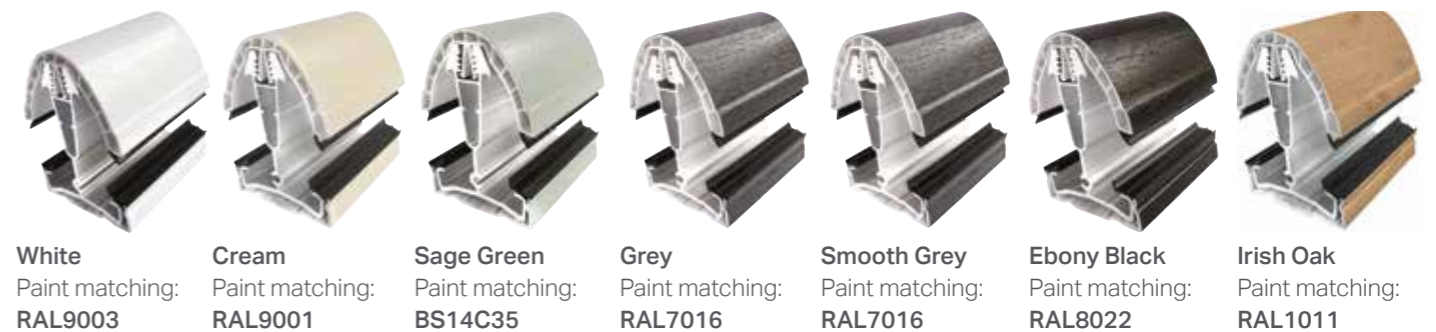

PREMIUM COLOUR OPTIONS

These PVCu conservatory roofs feature major parts that are actually foil laminated, with only a minority of parts actually painted.

The foil laminated products used on major items in the PVCu roof and on the PVCu side frames, have a real woodgrain texture to add a further dose of character. The products can be coloured one side or both, with the possibility to mix colours between the outside and the inside.

Standard foils: rosewood, light oak and mahogany.

- Many major parts are coloured foils.
- A viable alternative to powder coated aluminium
- Matching PVCu side frames in the same foil colours are widely available in the market
- The perfect complement to painted side frames on timber conservatories
- Can't see the colour you want? Ask for a bespoke colour and we'll paint the roof.
- For full specification on which items are foiled / painted, please see next page.

COLOURED FOILED PRODUCT CHART

Item	Supplied Foiled*	Supplied Sprayed
Glazing Bar	Top Cappings Internal Claddings Bolster Covers Lean-to Cloaking Trim Muntin Bars Glazing End Channel End Caps	
Eaves Beam	Internal Cladding (PFTC) End Channel	Polysupport - To Internal Colour Under Gutter Trim. (White on white roofs & black on other colours). Internal Fascia Corners.
Classic Ridge	Undercladding and internal radius end Internal Half Ridge Undercladding Vented Wallplate Internal Vented Wallplate External External Ridge Capping* and radius ends Internal Radius Ends External Radius Ends	Pikestaff Finial Low Profile Finial Low Profile Cresting Renaissance Cresting Ball Finial External Half Ridge Capping Flashing Trim Half Ridge External Radius Ends Half Ridge and Vented Wallplate End Caps Gable End Cappings
Slimline Ridge	Undercladding	External Ridge Body
Colours		Coloured Marley Classic Gutter (Supplied at additional cost)
Gutter		White Marley Classic Gutter on white roofs Black** Marley Classic Gutter on other standard
Box Gutter	Undercladding	Multiboard - Raised Back Box Gutters Adaptors
Valleys	Internal Claddings	External Cladding
Roof Vents	Mahogany ,rosewood, light oak and anthracite flat matt are foiled.	Sprayed. Motors are white on white roofs and black on other coloured roofs.

Specification / notes

Dome chambered cappings supplied as standard. Choose from low profile, Renaissance cresting and Pikestaff or Ball finial. A chrome tie bar is specified on internally coloured roofs. White tie bars are used on white foiled roofs.

* On a white foiled roof, the only parts available foiled are glazing bar top caps, undercladdings, PFTC internal cladding, ridge undercladding, valley internals, box gutter undercladding, vented wallplate undercladding, half ridge undercladding, end channel, muntin bars and lean-to cloak trim. Remainder is standard body colour white.** Black Marley is RAL9005

A coloured conservatory consists of foiled and painted parts. Every effort is made to ensure gloss levels are within reasonable tolerance. RAL and BS colour references are made in good faith - always give a sample swatch to your supplier when ordering any other parts (frames, cills etc) to match.

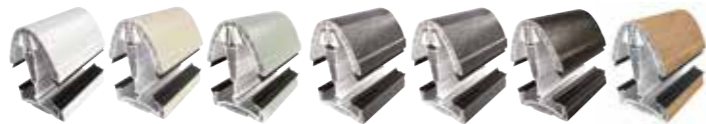

Carefully chosen colours create a space that works best for you and your home. Consider this...

- Black: powerful, sophisticated, elegance
- White/cream: calm, clean, sophisticated
- Green: harmony, balance, renewal

- Grey: calm, secure, reliable
- Brown: stable, comforting, enduring

OTHER CONSERVATORY DESIGNS

The Ultraframe roof system is truly configurable, that's why we can undertake more shapes and styles than any other system - in fact, it's why we are market leader.

PAGODA

By having an intermediate beam at right angles to the roof slope, we can create a stunning design and allow the use of differing glazing materials 'North and South' of the beam. The beam allows the roof to be used on even bigger conservatories before a portal frame is needed to give additional support.



WOKS

Why the weird name for this style? Because the ridge end caps look like the large pans used to cook chinese food! There can be full woks (360°), half woks or quarter woks. A further demonstration of the configurability of the Glass roof.



Full Wok



QUARTER WOK



Three Quarter Wok



Lanterns

Similar to a Pagoda, where a roof slope is split in two, but with an extra row of windows mid slope. Stunning on certain period homes.



LINKED TECHNOLOGIES - ALUMINIUM

Further enhancing the proven technology used in Ultraframe's Glass roof, the Ultraframe Glass Aluminium suite combines state-of-the-art ideas and design technologies with elegant, contemporary profiles to provide a strong, rigid yet lightweight system that can be configured into virtually any roof design.



BASE OFFER

- Aluminium glazing bar top caps.
- Aluminium ridge body and aluminium low profile cresting.
- Aluminium cast ridge end, integral brush and weathering flashing (or downgrade to PVCu radius end).

UPGRADE OPTIONS

- Aluminium cresting.
- Aluminium muntin.*
- Aluminium glazing end profile.*
- Aluminium decorative Cornice with die cast aluminium corner covers in 135° and 90° angles (Straight jointers too).
- Aluminium vent available.

* When Cornice is specified, these items are supplied in grey RAL 7016. This applies also to glazing bar end caps.

TRANSOM TOP CAPS

When selling the Ultraframe Glass aluminium roof, retailers have the choice between two different shaped transom top caps; a contemporary and a traditional option.

All Ultraframe top caps in the range utilise innovative Schlegel Q-lon gaskets which are inserted into the glazing bar top cap slots. Due to their unique design shape, when under compression, these gaskets create a double weatherseal, remaining operational and elastic even in the worst of weather conditions, without any loss in seal.

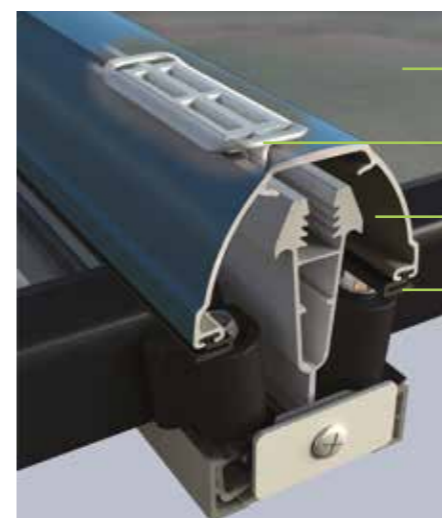

Code: ATC/25

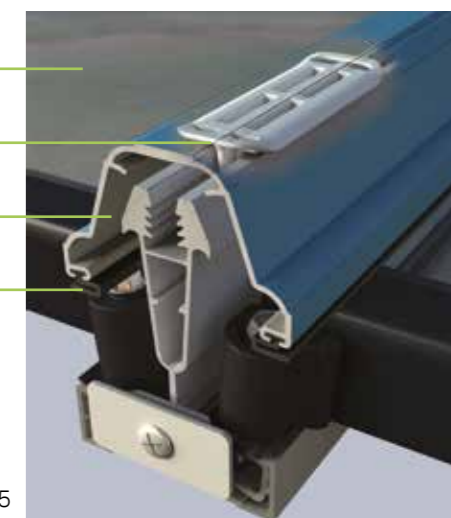

Code: AOC/25

COLOUR OPTIONS

The Ultraframe Glass aluminium roof is available painted in a wide range of RAL specified colours. Choose a traditional white colour or break the mould with a contemporary grey or black roof. Virtually any other colour you can imagine can be matched using the RAL colour system.



CORNICE

A decorative cornice adds shape and style to any roofline, concealing gutters and rafter ends. Best of all there are 4 styles to choose from. Design the width of your internal pelmet to suit your new room from 300mm to 1200mm. The added insulation in the pelmet will ensure your new orangery or extension is always warm, welcoming and cosy.

Curved Cornice includes a die cast 135° and 90° corner cover as well as straight jointers, which will help fitters achieve a consistent fit and finish at critical junctions. 1, 2 & 3 tier Cornice ONLY 90° corners and straight jointers available.



TOP CAP CLIPS

The Ultraframe Glass aluminium roof also takes a different approach to top cap retention.

To ensure that there is a constant thermal break and that no fixings puncture the primary weatherproofing, Glass roof uses injection moulded polycarbonate clip which is simply 'zipped' into the aluminium top cap whilst the roof is being built.

These clip security devices are then deployed at the top and bottom ends of the glazing bars and at 500mm centres and with no more than the heel of the hand - the top cap is finally secured.

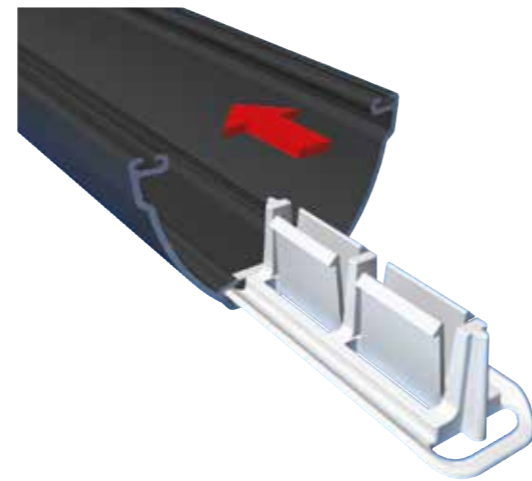

INSULATED INTERNAL PELMET

Insulated internal pelmet is the best of both worlds, combining the light and sky of a conservatory with the walls and ceiling of an extension.

Insulated internal pelmet is truly multi-functional, creating a pleasant and relaxing space for meditation or it can be a 'full on' family room. Insulated internal pelmet offers more, lots more than either a conservatory or an extension. Consider these benefits when choosing Ultraframe's Insulated internal pelmet which features the Glass roofing technology.

- Enjoy the light from a conservatory with the feel of an extension -providing greater overall value and the best of all worlds.
- Creates a whole new dynamic to the space - a 'real room/living room' feel.
- You can maintain light and space by using windows all round, have brick piers to give a greater sense of solidity or now specify super-insulated columns.
- Better thermal efficiency when compared to a standard conservatory - pelmet can be filled with insulation quilt for even better thermal performance.
- This real room/living room feel means more styling and furnishing options and the perimeter ceiling is perfect for down lighters.
- Variable pelmet depth, 300 - 1200mm.



Super-insulated column - replaces brick piers. See separate brochure for more information.



Illustration shows below fascia option

VERANDA GLASS EXTENSION

Conservatories have always been an excellent way for consumers to blur the margin between home and garden, but Ultraframe is taking the idea to a new level with its Veranda glass extension.

The light, bright and airy interior will add a new dimension to your home and provide a seamless link between your home and garden.



SYSTEM ELEMENTS

At the core of the Veranda is the Glass roof. At the intersection between internal and external space is the Super Duty Eaves Beam*, clad internally with the PFTB planked fascia and externally with a powder coated aluminium fascia.

The main Veranda beam is constructed from powder coated aluminium and acts as an integral gutter and support beam. Posts are part of the structural support package. There are two types of post - aluminium or oak. The oak post comes complete with gasketed stopends and splice plates to connect to the base.

An alternative to the oak post is the aluminium support post - this can mutually fulfill 2 functions when fabricated, as rain water pipe and post.

* On certain Veranda designs and on very wide openings, a 'goal post' support arrangement will be necessary and of course Ultraframe can design and manufacture this.



Rain Gutter detail

COMPARE THE ULTRAFRAME GLASS ROOF WITH SOME ALTERNATIVES

Having read this guide to the Glass Roof technology, you will have some idea why it is not only the best on the market, but why it is the most popular amongst the trade and satisfied homeowners too - after all, 1,500,000 satisfied customers can't be wrong, can they?!

Reasons to choose Ultraframe... outlining the Glass roof features and benefits

FEATURE	BENEFIT
Over 1 and a half million Glass conservatory roofs installed to date.	Tried, tested and trusted. The ultimate in peace of mind as you know the roofs are performing day in day out in all that the UK climate can throw at it.
The first conservatory roof to be BBA approved.	In 1996 we were the first to submit roofs for independent 3rd party accreditation.
Glass roof regarded as the most versatile system on the market	A sales team have the confidence that whatever design/style/shape they sell Glass roof can accommodate it.
Unique ridge ventilation as standard	Helps the homeowner to control internal air movement and internal temperatures.
Eavesbeam ventilation is optional	Combine ridge trickle ventilation with Eavesflow and you have the perfect combination of cross flow and convection working in tandem - effective minimisation of condensation. Excellent thermal performance makes the conservatory warmer in winter - shape options for more choice.
PVCu twinwall glazing bar top cappings	No other 'traditional' roof comes close: 4 deg C (40%) warmer than competitors top caps.
The most thermally efficient 'traditional' roof on the market	Speedy glazing bar attachment at the ridge with speedloks
Revolutionary effective Tie Bar Replacement Kit	Remove unsightly tie bars with confidence
Reliable gable roof frame support system	Eliminate frame wobble, particularly under double doors and remove the need for extra soak aways - saves money on site and looks good. Use on gable fronted and lean-to's
Wide range of customer options	From interior pelmets to external Cornice Glass it is all highly configurable
Conservafash - Unique lead free flashing kit	Further speed up installation with the combined soaker and stepped PVCu flashing - save time and money over lead
Engineered structurally proven jack rafter connecting kits	Whether it's wind uplift or heavy snow load, the connection point is strong and waterproof
Glass roof offers the widest selection of finials and crestings	With Glass roof, you are not stuck with one choice - Easyclean versions also
Fully insulated boxgutters to suit all possible applications	Reduces the chance of condensation
Extensive choice of optional glazing materials	From basic to high performance, there are options for all budgets which means that homeowners with varying budgets can access our technology

Spot the difference between key components and a hybrid of features available from others...

ULTRAFRAME BARS

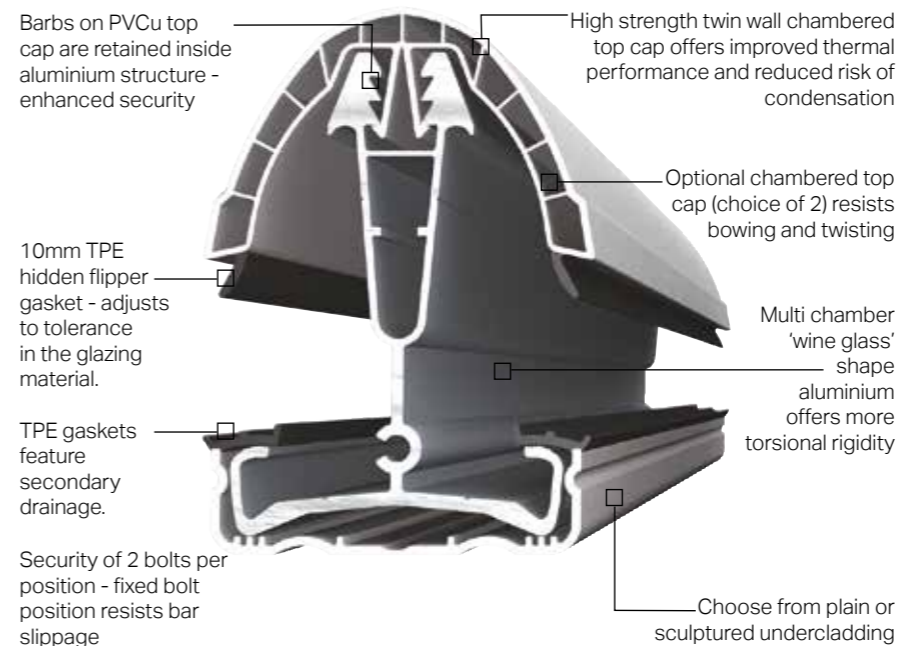

ALTERNATIVE'S FEATURES

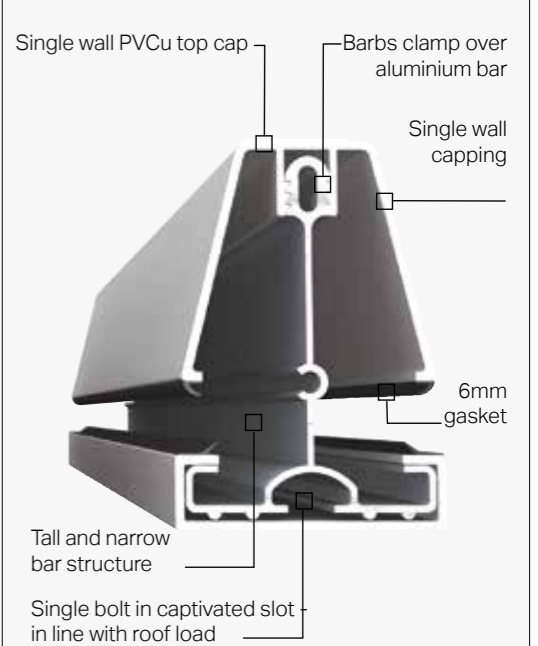

ULTRAFRAME EAVES BEAM

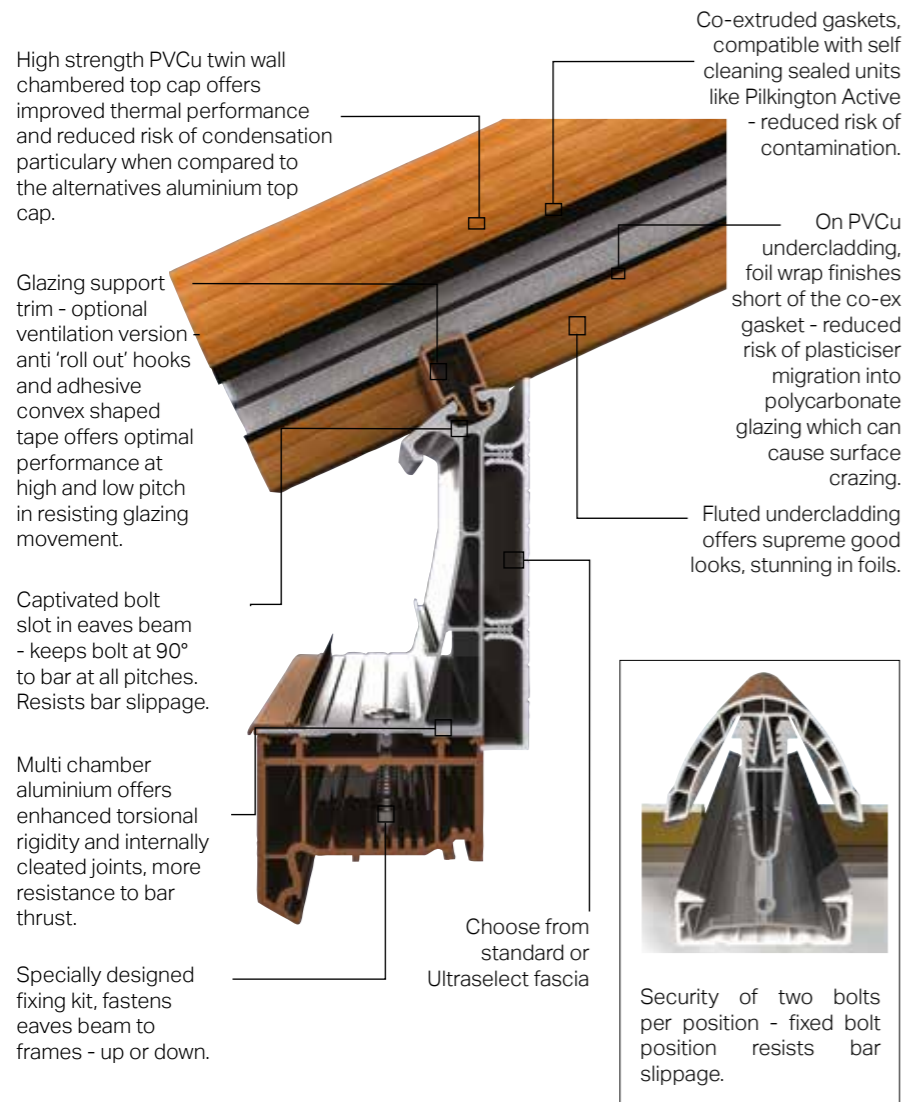

ALTERNATIVE'S FEATURES

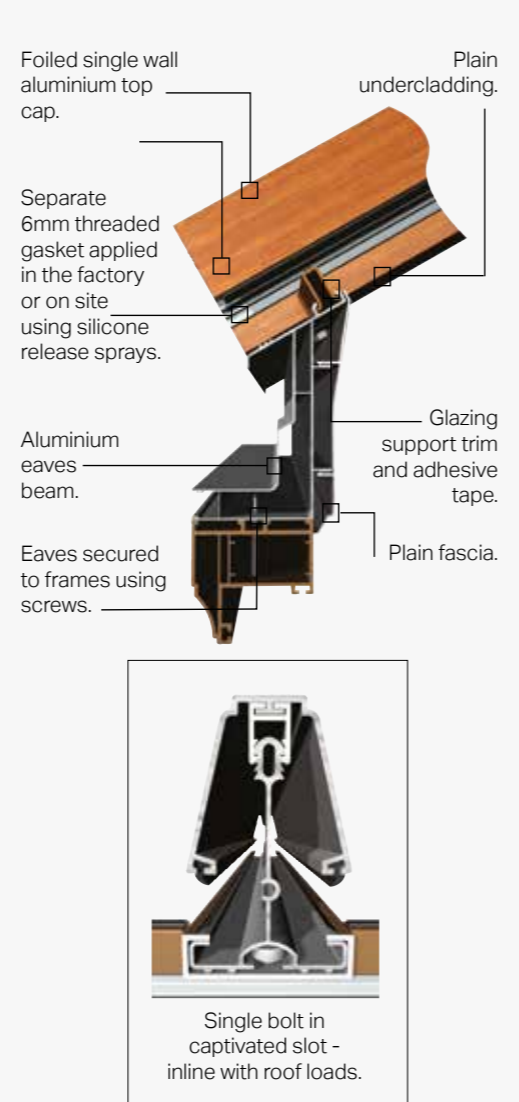

ULTRAFRAME JACK RAFTER

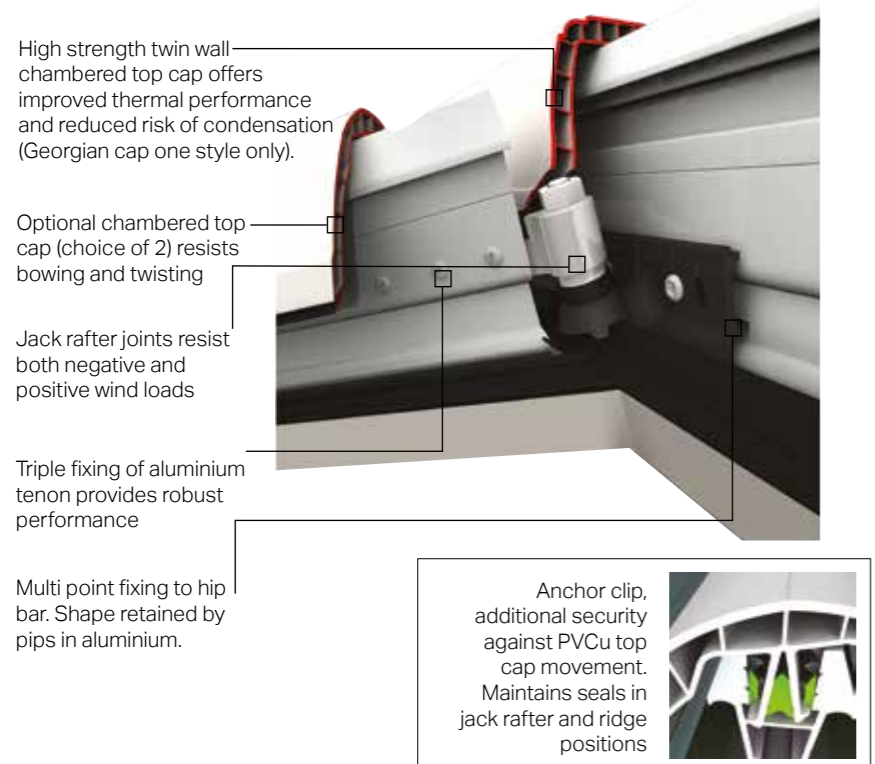

ALTERNATIVE'S FEATURES

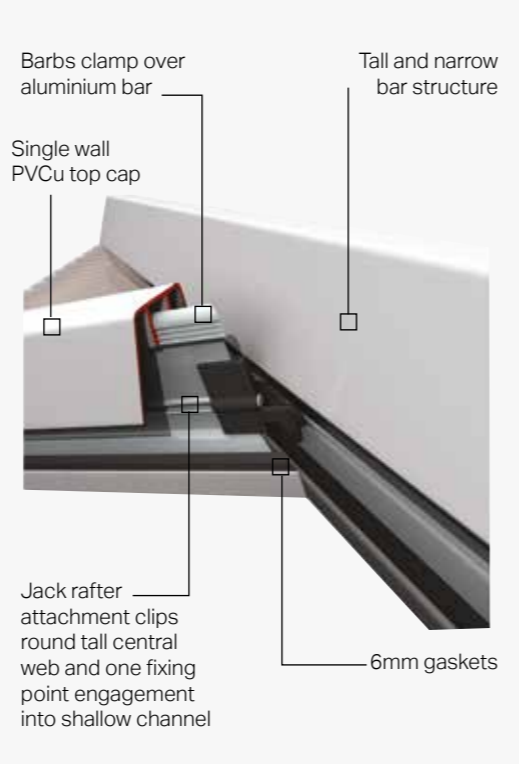

hup!

Glass Roof



The Glass Roof is available with the hup! walling system from Ultraframe. The Glass Roof can be supplied with a hup! mini pelmet as shown below, or the internal pelmet can be widened to up to 1200mm making it the perfect place for spotlights or speakers.

A top tray runs along the top of the hup! walls underneath the eaves beam. The clips are screwed under the top tray. Raked frames must be used on lean-to roofs as the walls cannot be raked and meet a glass panel/starter bar. Internally the top tray meets the edge of the internal pelmet or it can be wider.

The external face of the window or door frames lines up with the panel clips on the external base datum. With traditional 70mm frames the internal frame line sits 70mm inboard of the external base datum. When claddings are added to the wall (c45mm) the window frames will sit 115mm inside the external wall datum.

Order hup! walls based on external base datum and deduct 70mm from each side to order the Glass Roof. See separate hup! walling specification guide for full details on the hup! walling system.

www.world-group.co.uk
01228 599777 or 01387 249777

Job No.: 2473 12/22 V12 CTG001

It is Ultraframe's policy to continually seek to improve its products, processes and services, and we reserve the right to change specifications without prior notice. Ultraframe is a trading name of Ultraframe (UK) Limited.



Ultraframe[®]
Transforming light and space